



*Manufacturers of Process  
Controls and Instrumentation*

## ***Instruction Manual***

Model: *IUC-XX*

Function: *Isolator*

Input:  X=1: 1-5 mA       X=4: 10-50 mA  
 X=2: 4-20 mA       X=5: 1-5 VDC  
 X=3: 0-1 mA       X=6: 0-10 VDC  
 X=7: \_\_\_\_\_

Output:  X=1: 1-5 mA       X=4: 10-50 mA  
 X=2: 4-20 mA       X=5: 1-5 VDC  
 X=3: 0-1 mA       X=6: 0-10 VDC  
 X=7: \_\_\_\_\_

Power:  117 VAC, 60 Hz, 6 VA  
 24 VDC, 160 mA  
 \_\_\_\_\_

Serial #: \_\_\_\_\_

(If special or required)

For Technical Assistance And Questions Call  
USA: (231) 788-2900    CANADA: (905) 660-5336

## Restocking Policy

**All product returned to Pribusin Inc. in prime condition (not damaged, scratched or defaced in any way) within seven (7) months from the original date of shipment is subject to a 50% restocking charge. All product must be accompanied by a Return Authorization number (RA number) which must be obtained from Pribusin Inc. prior to returning any product.**

**After seven (7) months from the original date of shipment, products cannot be returned for restocking.**

**Custom designed products, modified products or all non-standard products may not be returned for restocking.**

## Warranty Policy

**Pribusin Inc. warrants equipment of its own manufacture to be free from defects in material and workmanship, under normal conditions of use and service, and will replace any component found to be defective, on its return to Pribusin Inc., transportation charges prepaid, within one year of its original purchase. Pribusin Inc. will extend the same warranty protection on equipment, peripherals and accessories which is extended to Pribusin Inc. by the original manufacturer. Pribusin Inc. also assumes noliability, expressed or implied, beyond its obligation to prelace any component involved. Such warranty is in lieu of all other warranties, expressed or implied.**



**Standard Features:**

High Input-Output-Power Isolation (1500VAC Test)

Industry Standard Inputs: 4-20 mA, 1-5 VDC, and more (see back)

Industry Standard Output: 4-20 mA, 1-5 VDC, more (see back)

Other Models Available for Millivolt, RTD, Thermocouple Inputs and more

High Output Drive on Current Outputs

Easy Field Calibration (Typ. calibration time < 2 min. using handheld meter only)

Microprocessor Controlled for High Accuracy

Two Wire Supply Option for Two Wire Transmitters

Power: 117 VAC 50/60 Hz (Optional 24 VDC)

High Noise Rejection

CSA and NRTL Approved (LR 51078)

**Function:**

The IUC-XX is an isolated signal conditioner that provides high isolation and rugged design for many control applications. Three-way isolation is provided between the inputs, the output and the power. The signal isolation takes place through state-of-the-art optical isolators to ensure high accuracy and repeatability. Special output drive circuitry allows the IUC-XX to drive loads of up to 1600 Ohms which makes it ideal for driving multi instrument loops.

Several other models with various special inputs are available in the IUC-XX family. These models include RTD and Thermocouple conditioners, Strain Gage and Slide Wire conditioners etc. The same high isolation and rugged design makes these instruments accurate and dependable.

**Calibration:**

Calibration is performed using easily accessible multi-turn potentiometers.. All instruments are shipped fully calibrated and tested, but can easily be field adjusted. A Zero and Span pot are available on all units to adjust the output signal.

**Specifications:**

Isolation: Input to Output to Power 1500 VAC (test)  
Accuracy/Linearity: +/- 0.1% max., +/- 0.05% typ.  
Operating Temperature: -40 Deg.C. to +50 Deg.C.  
Temperature Effects: +/-0.5% max., +/-0.2% typ.  
(for 40 Deg.C. change)  
Output Ripple: less than 0.1% p-p value  
Common Mode Rejection: 120 dB @ 60 Hz  
Loop Drive: Max. 1600 Ohms at 20 mA

# IUC-XX

## Enclosures & Dimensions:

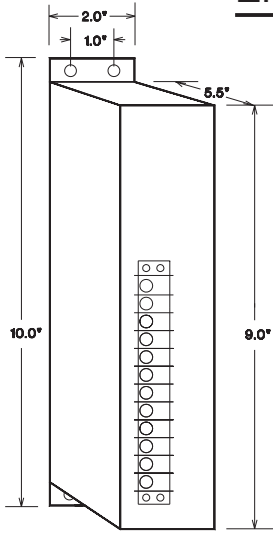

Standard Metal Enclosure

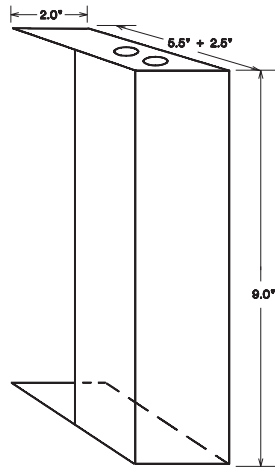

Conduit Cover Option for Metal Enclosure

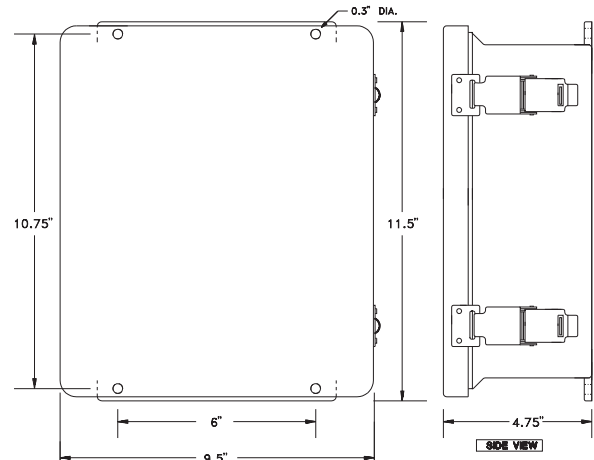

NEMA 4X Option

## Connection:

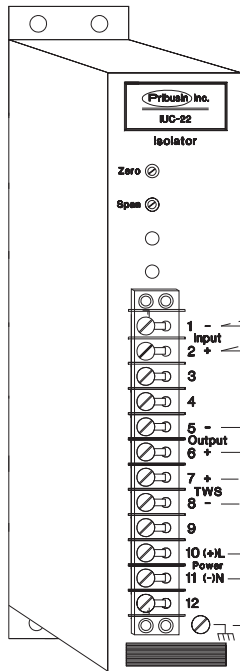

Shown here for 4-20mA Input and Output

### Optional TWS Connection

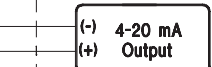
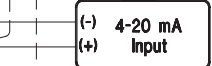
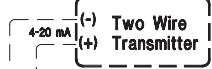

Not Required (Connected Internally)



## Model Designation:

IUC - X X

Input

Output

- 1: 1-5 mA (Zin=1K Ohm)
- 2: 4-20 mA (Zin=250 Ohm)
- 3: 0-1mA (Zin=5K Ohm)
- 4: 10-50 mA (Zin=100 Ohm)
- 5: 1-5 VDC (Zin=1Meg Ohm)
- 6: 0-10 VDC (Zin=1Meg Ohm)
- 7: Special Input

- 1: 1-5 mA (4000 Ohm Drive)
- 2: 4-20 mA (1000 Ohm Drive)
- 3: 0-1 mA (20000 Ohm Drive)
- 4: 10-50 mA (250 Ohm Drive)
- 5: 1-5 VDC (Zout=250 Ohm)
- 6: 0-10 VDC (Zout=500 Ohm)
- 7: Special Output

Example: Isolator with 4-20 mA Input and 4-20 mA Output in standard metal enclosure and 117VAC Power is designated by:IUC-22

If no options specified, unit is 117 VAC Power in metal enclosure

## Options: (Add letters to end of Model Number)

- A - 24 VDC Prime Power
- B - 240 VAC Prime Power (not CSA approved)
- T - 200 mA Two Wire Supply (24 VDC unreg.)
- C - Conduit Cover for Metal Enclosure (see above)
- N - NEMA 4X enclosure (see above)

Manufactured By:

**Pribusin Inc.**

www.pribusin.com  
info@pribusin.com

### USA:

Pribusin Inc.  
743 Marquette Ave.  
Muskegon, MI 49442  
Ph: (231) 788-2900  
Fx: (231) 788-2929



### CANADA:

Pribusin Inc.  
101 Freshway Dr. Unit 57  
Concord, Ontario, L4K 1R9  
Ph: (905) 660-5336  
Fx: (905) 660-4068

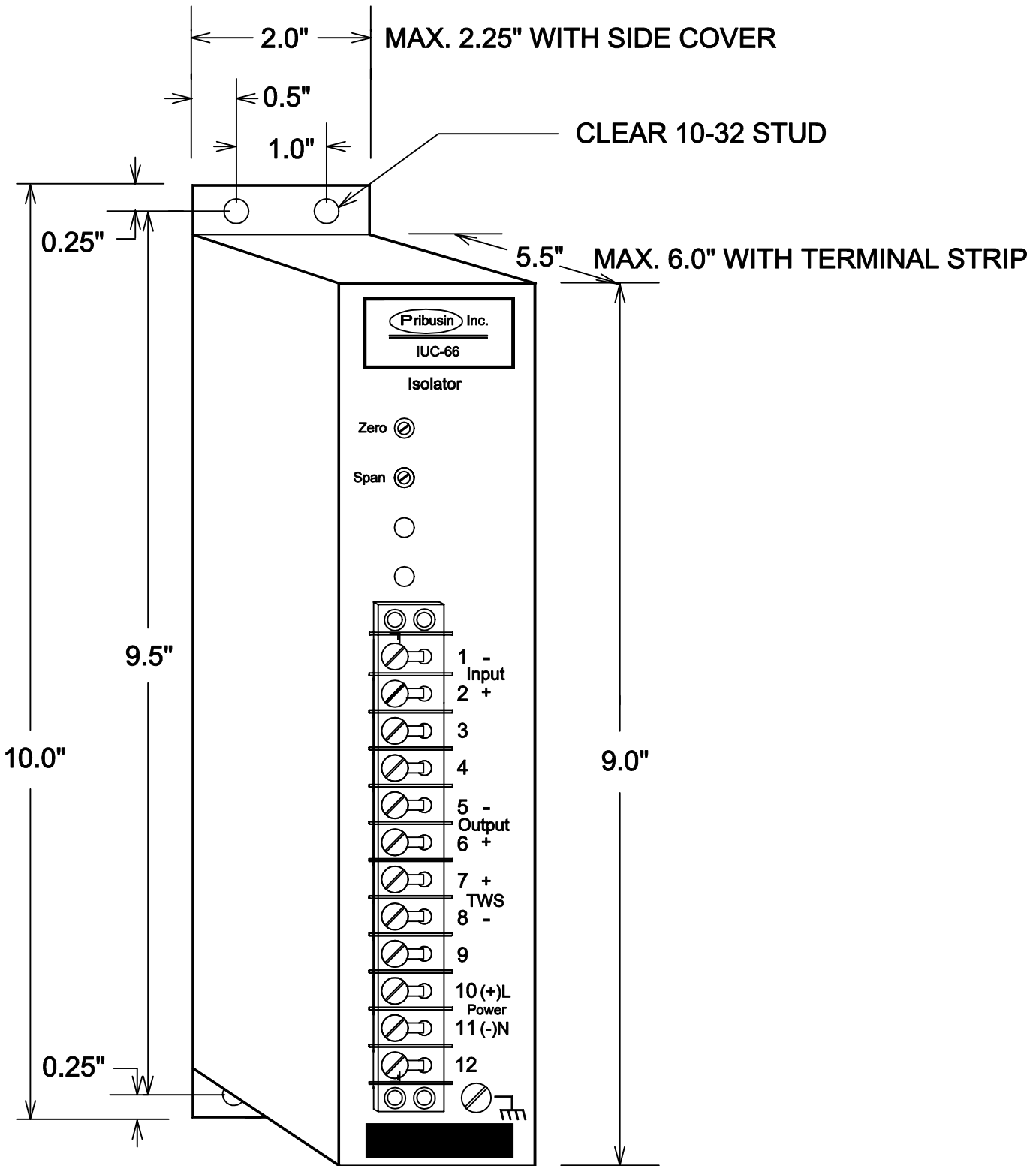

<b>Pribusin Inc. ©</b>		
CHKD:	DATE: MAR. 04/93	DRN: KS
MODEL: IUC-66 ISOLATOR ENCLOSURE DRAWING		
DWG. NO.:	104311	REV. A

### Calibration :

The only calibration that can be done is output ZERO and output SPAN.

1. Apply an input of 0 VDC to terminals 1 and 2.
2. Adjust ZERO until output signal is 0 VDC.
3. Apply an input of 10 VDC to terminals 1 and 2.
4. Adjust SPAN until output signal is 10 VDC.
5. Repeat procedure starting at 1. until output signal is correct.
6. Apply an input of 5 VDC to terminals 1 and 2, and check that the output is 5 VDC.
7. Calibration is complete.

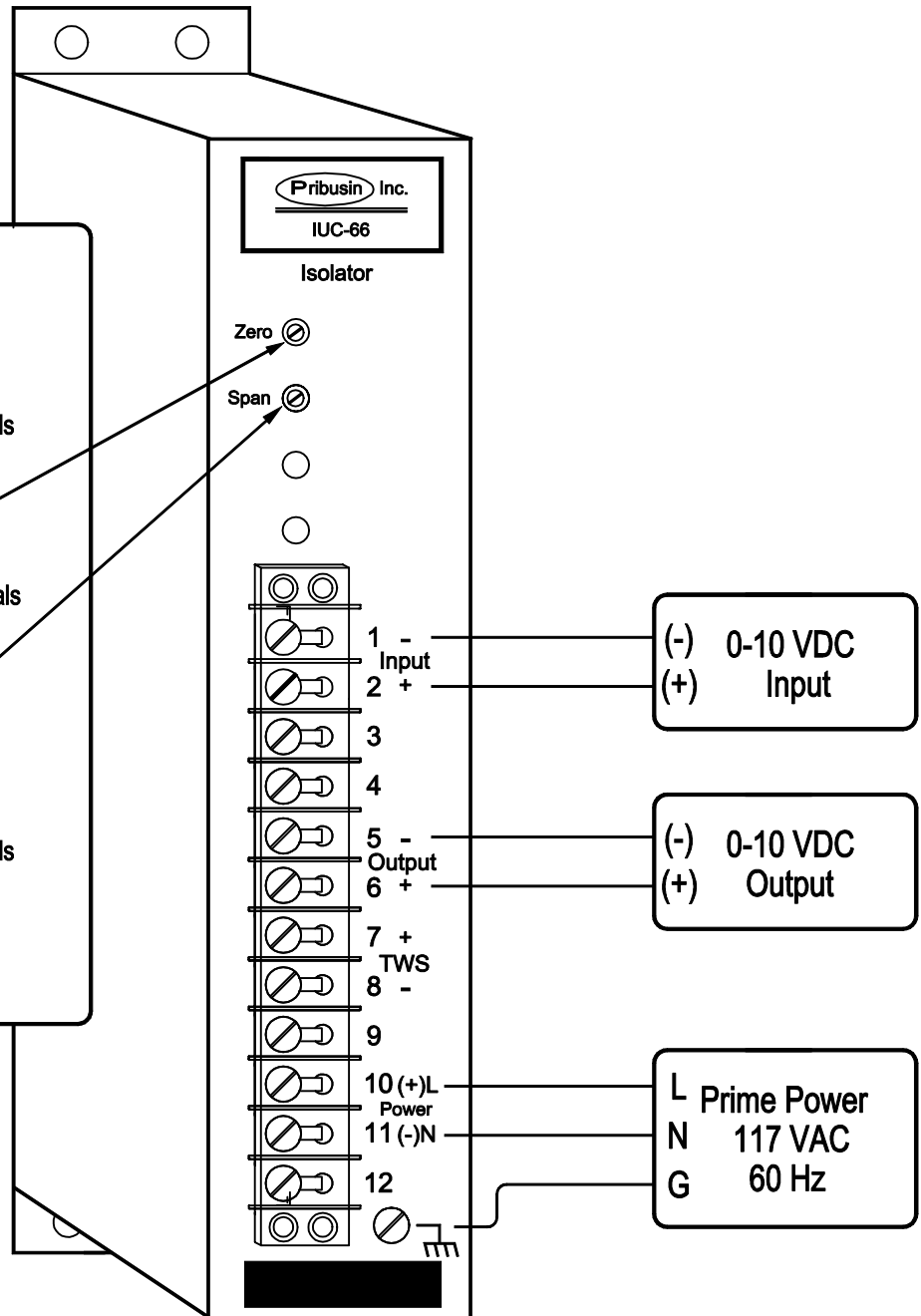

**Pribusin Inc. ©**

CHKD:      DATE: MAR. 04/93      DRN: KS

MODEL: IUC-66  
ISOLATOR  
CONNECTIONS/CALIBRATION

DWG. NO. :      104312      REV. A