



*Manufacturers of Process
Controls and Instrumentation*

Instruction Manual

Model: *RCI-200-XXX*

Function: *Remote Control Signal Interface*

Communication: *XXX=SER: RS-232/485*
 XXX=MDM Modem Dial-Up
 XXX=FSK: Leased Line
 XXX=RF9: 900 Mhz Wireless
 XXX=NET: Ethernet (TCP/IP)

Input: 2 "Dry" Contacts and 2 Analog Inputs

Output: 2 Form 'C' Contacts and 2 Analog Outputs

Power: 117VAC, 50/60Hz
 24 VDC

Serial #: _____

(If special or required)

For Technical Assistance And Questions Call
USA: (231) 788-2900 CANADA: (905) 660-5336

Restocking Policy

All product returned to Pribusin Inc. in prime condition (not damaged, scratched or defaced in any way) within seven (7) months from the original date of shipment is subject to a 50% restocking charge. All product must be accompanied by a Return Authorization number (RA number) which must be obtained from Pribusin Inc. prior to returning any product.

After seven (7) months from the original date of shipment, products cannot be returned for restocking.

Custom designed products, modified products or all non-standard products may not be returned for restocking.

Warranty Policy

Pribusin Inc. warrants equipment of its own manufacture to be free from defects in material and workmanship, under normal conditions of use and service, and will replace any component found to be defective, on its return to Pribusin Inc., transportation charges prepaid, within one year of its original purchase. Pribusin Inc. will extend the same warranty protection on equipment, peripherals and accessories which is extended to Pribusin Inc. by the original manufacturer. Pribusin Inc. also assumes noliability, expressed or implied, beyond its obligation to prelace any component involved. Such warranty is in lieu of all other warranties, expressed or implied.



Standard Features:

Bi-directional Communication using Ethernet/Internet
Point-to-Point Operation
2 Dry Contact and 2 Analog Input
2 'C' Relay Contact and 2 Analog Output
No Calibration Required
Microprocessor Controlled for High Accuracy
Power: 117 VAC 50/60 Hz (Optional 24 VDC)
High Noise Rejection

Function:

The RCI-200-NET is a bi-directional ethernet communication system that exchanges the status of 2 dry contact input and 2 analog input between a host and remote unit or an ethernet enabled device . A basic system consists of A) one host station and one remote station **OR** B) several remote stations and one PC or ethernet enabled device.

In system A), the host unit continually interrogates the remote unit and exchanges its inputs and outputs. Inputs from the host are sent to the outputs of the remote while inputs from the remote are sent to the outputs of the host.

In system B), an ethernet enabled device can access any remote unit and monitor the inputs and control the outputs.

Connection:

Units are connected via a standard 10/100 Ethernet. Regular RJ45 Jacks make for easy installation.

Specifications:

Transmission Medium: 10/100 Ethernet, RJ-45 connection
Operating Temperature: -20 Deg.C. to +50 Deg.C.
Relay Contacts: 10A 1/8Hp @ 125VAC
6A 1/8Hp @ 277VAC
Power: 117 VAC, 60/50 Hz
(24VDC Available)
Enclosure: NEMA4X (NEMA12 available as an option)

RCI-200-NET

Enclosures & Dimensions:

Options: (Add letters to end of Model Number)

D - 8-Digit Scanning Display

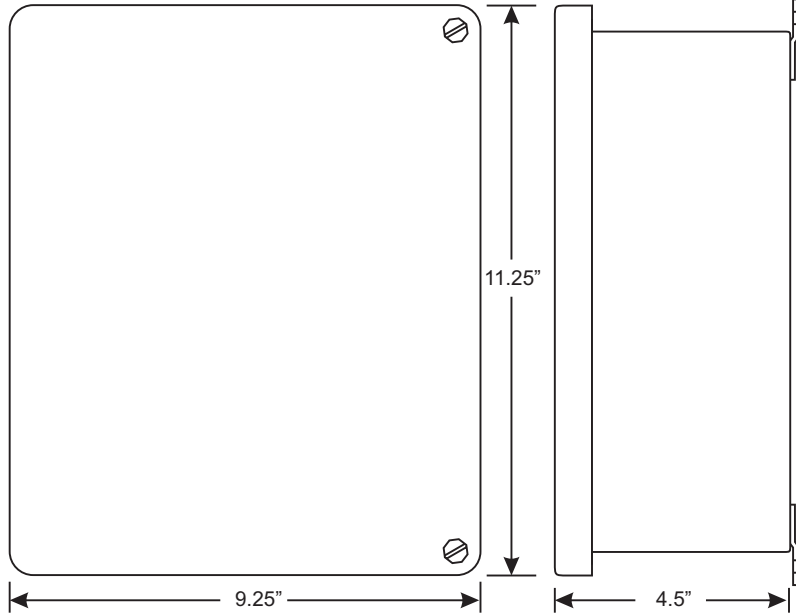

Connection:

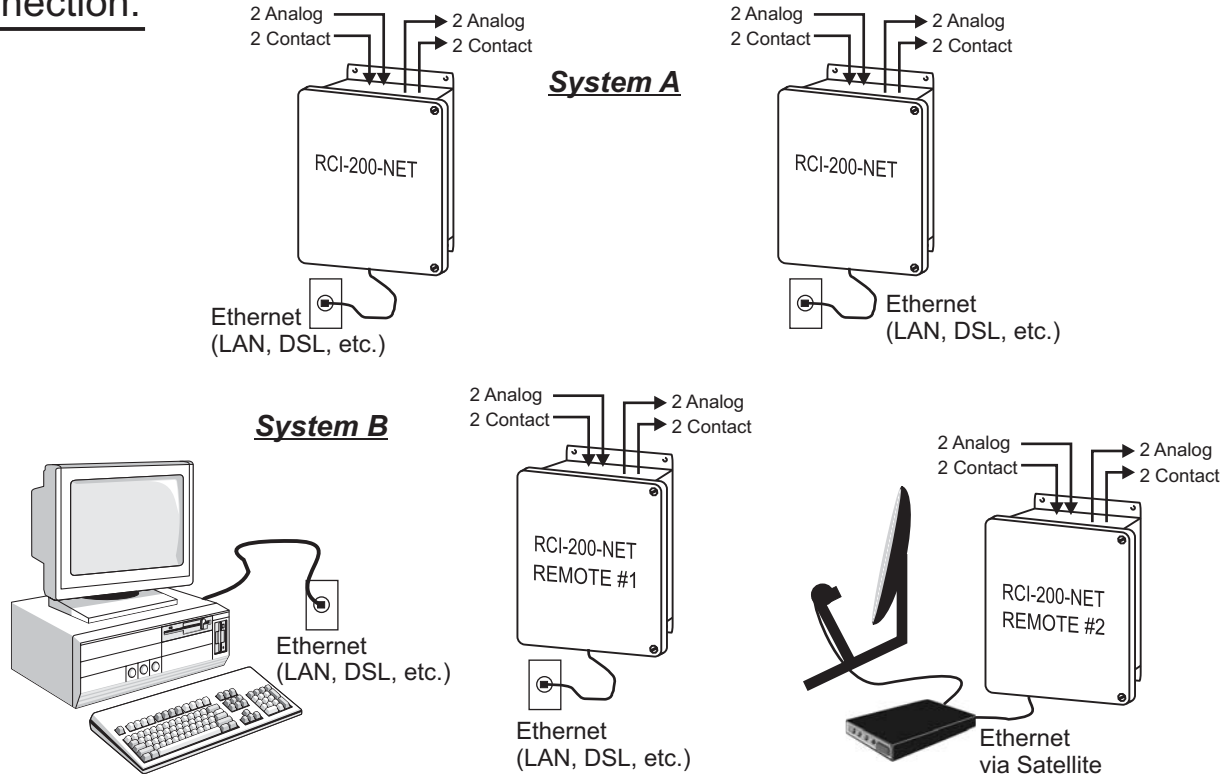

Manufactured By:

Pribusin Inc.

www.pribusin.com
info@pribusin.com

USA:

Pribusin Inc.
 3938 Trade Center Drive
 Ann Arbor, MI 48108-2072
 Ph: (734) 677-0459
 Fx: (734) 677-0861



CANADA:

Pribusin Inc.
 101 Freshway Dr. Unit 57
 Concord, Ontario, L4K 1R9
 Ph: (905) 660-5336
 Fx: (905) 660-4068

Mounting_Holes
6.02"

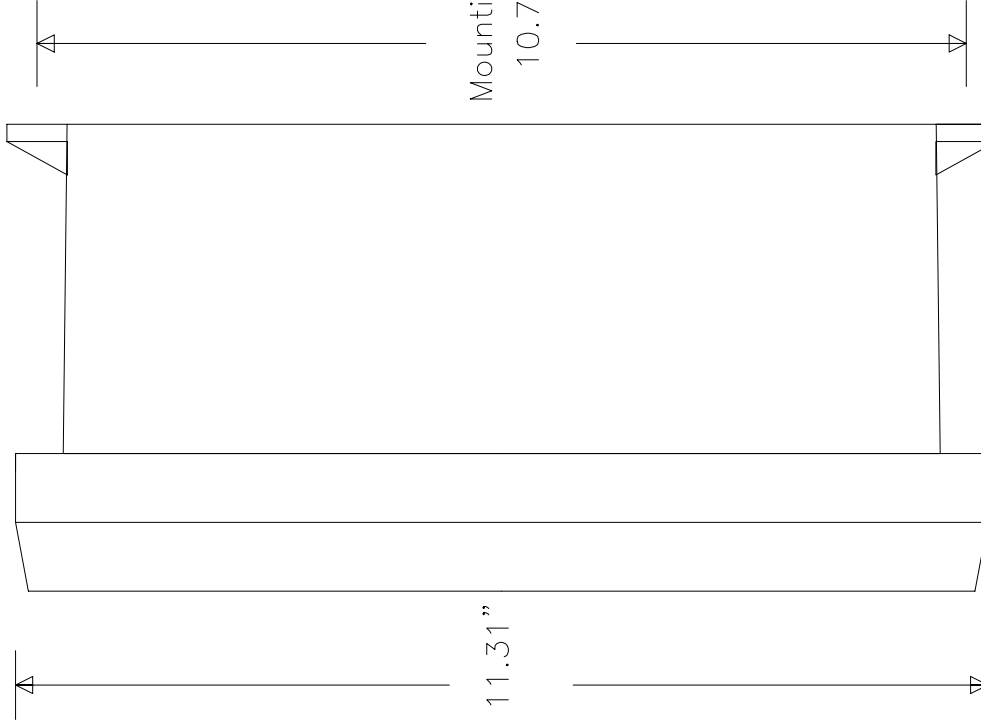

Pribusin Inc. ©	
CHKD: V.B	DATE: MAY14/10
DRN: D.P	
RCI-200 ENCLOSURE DIMENSION	
DWG. NO.: 108125	REV. A

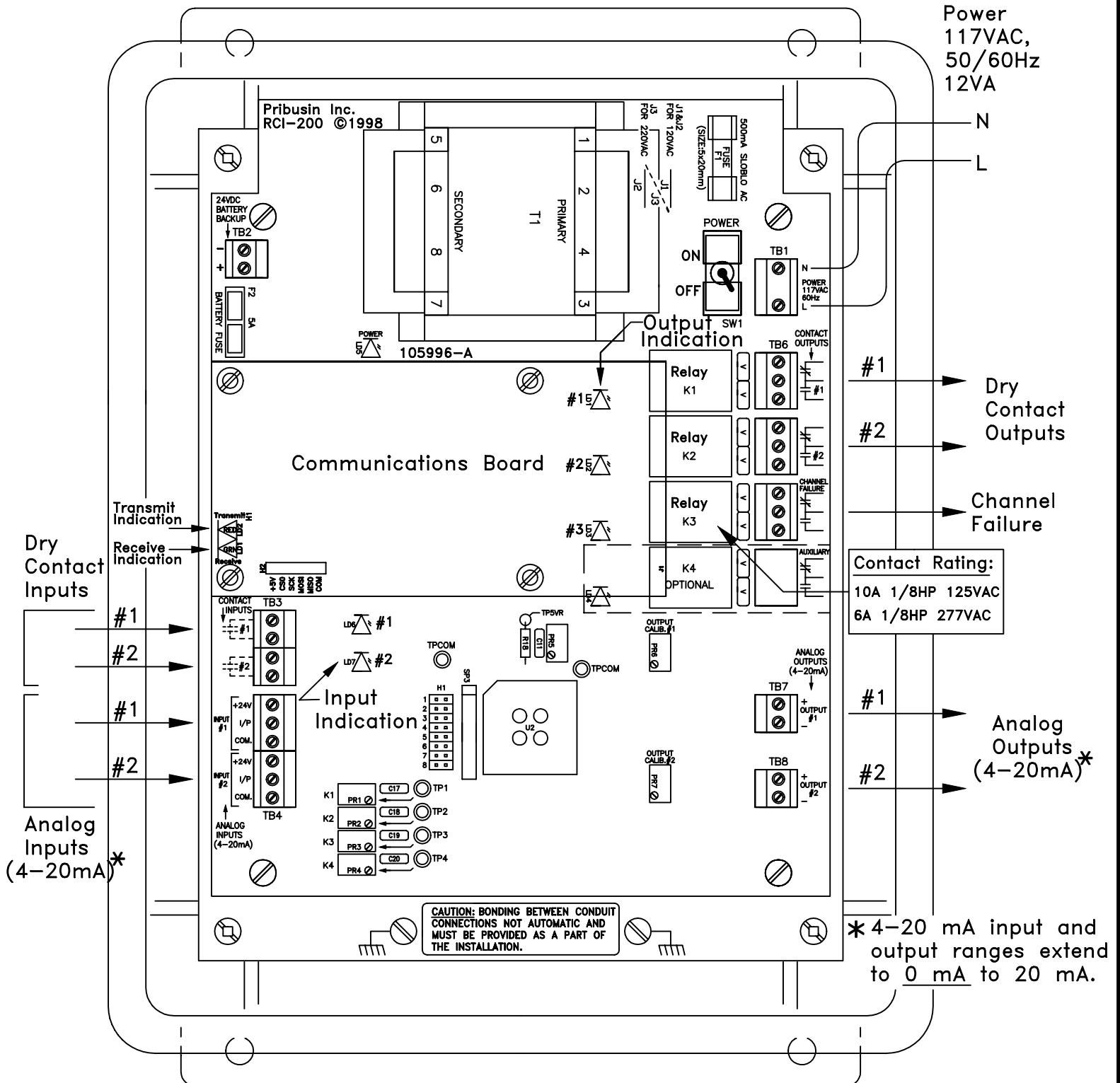

Power
117VAC,
50/60Hz
12VA

N
L

#1 → Dry Contact Outputs
#2 → Dry Contact Outputs
Channel Failure

Contact Rating:
10A 1/8HP 125VAC
6A 1/8HP 277VAC

#1 → Analog Outputs (4-20mA)*
#2 → Analog Outputs (4-20mA)*

* 4-20 mA input and output ranges extend to 0 mA to 20 mA.

Pribusin Inc. ©		
CHKD :	DATE : Apr. 15/99	DRN : KS
Model: RCI-200-XXX Remote Control Signal Interface		
DWG. NO. :	106125	REV. B

RCI-200 Connections:

The RCI-200 is the main board of an RCI-200-XXX Telemetry system. It provides the input and output signal connections as well as the power supply for the unit. A separate communications board is added to the RCI-200 to allow it to communicate with other units. This communications board may have its own configuration that is in a separate section of this manual. The following configuration applies only to the RCI-200 board and is common to all communications interfaces.

AC Power & Fuse:

The RCI-200 is typically powered from 120VAC and protected by a 500mA SLOBLO fuse. It can be wired for 240VAC operation by removing (desoldering) power jumpers J1 & J2 and installing (soldering) jumper J3.

When changing the RCI-200 to 240VAC power make sure to change the fuse to half of its value, 250mA. This is important since at 240VAC the RCI-200 requires only half the current as if it were powered from 120VAC. Proper protection is only achieved by reducing the fuse value as mentioned above.

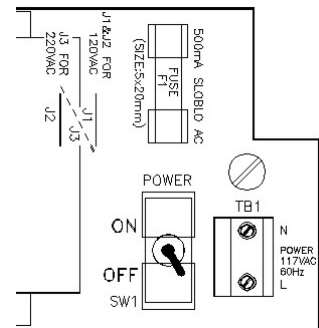

DC Power & Battery Backup:

The RCI-200 may also be powered from a 24VDC source which could be a battery or a DC power supply. The 24VDC power input is polarity protected with a fuse to prevent damage to the RCI-200 by inadvertent reverse polarity. A DC fuse provision is also provided if this power option is utilized. Insert a 5A automotive type blade fuse into the Battery Fuse socket.

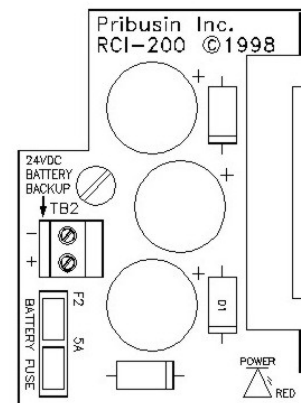

Inputs:

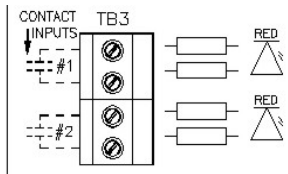

The RCI-200 has two dry contact inputs and two 0-20mA inputs. The dry contact inputs are excited with 24VDC and will source approximately 20mA when the contact is closed. A red LED lights up when a contact input is closed.

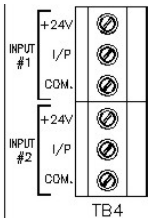

The analog inputs are configured as 0-20mA inputs and have a 250Ω input impedance. Each input terminal has three connections: +24V, I/P, COM. The +24V power output may be used to power field transmitters. Up to 500mA may be used to power a transmitter. The input signal is connected to I/P(+) and COM(-).

Analog inputs are connected to the RCI-800 in two fashions: 1) Normal (3-wire connection) or 2) two-wire connection. On a 3-wire connected input, an external power supply or the +24V power output terminal of the RCI provides power to the field transmitter. The field transmitter has a current source that provides the 4-20mA signal back to the RCI-800. If using the power supply of the RCI-800, the field transmitter may draw up to 125mA. A total of 1A is available to power up to 8 field transmitters.

On a 2-wire connected input, the field transmitter receives power from the RCI-800 and superimposes the signal onto the power return path. A maximum of 20mA will flow in such a connection. Make sure to consult the field transmitter manual to determine how to connect it to the RCI-800.

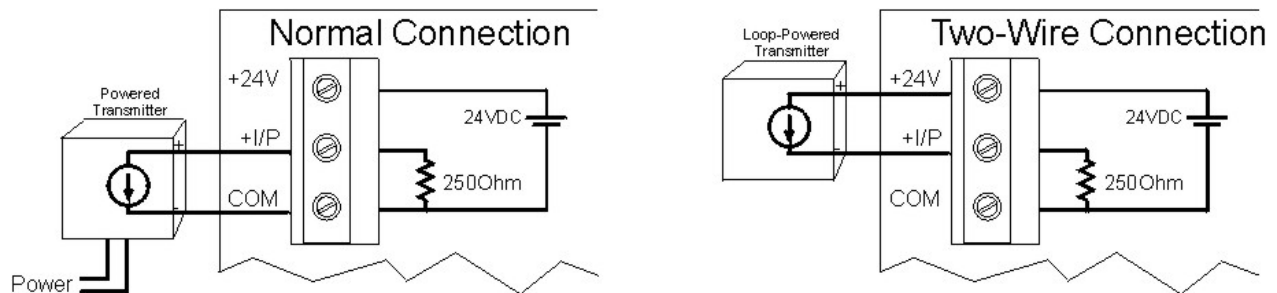

Outputs:

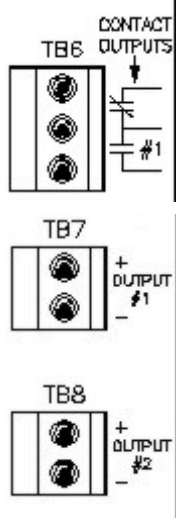

The RCI-200 has two form 'C' relay contact outputs and two 0-20mA analog outputs. The relay contacts are capable of switching 120VAC, 10A or 240VAC, 6A. An energy absorbing varistor is installed across each contact to limit switching transients. A third relay contact acts as a communications fail indicator. If no communication occurred within 30 seconds, this relay contact will energize. Upon re-established communication this relay will de-energize again.

The two analog outputs are typically configured as 0-20mA outputs and can drive into a 1000Ω load each, provided that the power supply to the unit is not below 24VDC. The outputs are not isolated from each other or from the inputs. Care must be taken when connecting the outputs to different devices so that no inadvertent ground loops are established.

Output Calibration & Input Testing:

The outputs on the RCI-200 are factory calibrated and should not require any adjustments. To check the calibration of the outputs and relays use jumpers H1-7 & H1-8 as shown below to set them to known states. If an output should require some adjustment, insert jumper H1-8 only and turn the OUTPUT CALIB. trim pot until the output reads 20mA.

H1-7	H1-8	Function
OUT	OUT	Normal Operation
OUT	IN	Outputs=20mA, Relays=Energized
IN	OUT	Outputs=0mA, Relays=De-energized
IN	IN	Outputs=Inputs, Relays=Contact Inputs

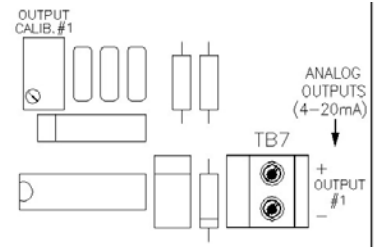

If both jumpers are IN the analog and contact inputs are passed straight through to the analog and relay outputs. This may help in troubleshooting input and output signals.

Make sure both jumpers are removed before resuming normal operation.

RCI-200 Configuration:

The RCI-200 requires no configuration other than for its communication fail operation. In the event of a communications failure on the communications board, the RCI-200 can be set up to take various actions on its outputs. This may be desirable in order to place connected devices into a safe operating mode. By default factory setting, all outputs remain at their last known state if a communications failure occurs.

H1-	Function	OUT	IN
1	Relay Fail Mode	No Change	See H1-2
2	Relay Fail Status	De-Energize	Energize
3	Output Fail Mode	No Change	Ramp to K1/K2*
4			
5			
6			
7	I/O Calibration		
8	I/O Calibration		

- * If H1-3=IN then analog output #1 will ramp to the setting of K1 and analog output #2 will ramp to the setting of K2. Both outputs will change at a rate determined by the setting of K3. The settings of the trim pots can be read on test points TP_{1,2,3} using a voltmeter. The test points read a voltage of 0-5V for a 0-100% adjustment.

$$TP_{1,2} = \frac{Output}{20} \times 5Volt \quad TP_3 = \frac{RampRate}{60} \times 5Volt$$

where, *Output* = 0-20 (mA) and *Ramp Rate* = 0-60 (seconds) (5 sec. minimum)

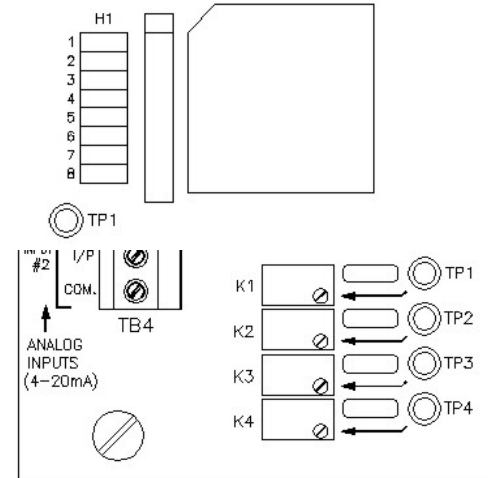

NET (Ethernet) Communication Option:

The –NET communications option to the RCI series utilizes serial tunneling via Ethernet to exchange the signal data between a host and a remote. Currently only point-to-point operation is supported.

In a **Point-to-Point** topology one host communicates with one remote. The two exchange all their signals with one another. The remote is configured as remote #1 even though it is the only remote in the system.

All configurations are done via two banks of DIP Switches. SW1 is not used and all positions must be OPEN. SW2 assigns the Remote and Host Channel Numbers and Host/Remote Mode. The switches are located on the communications board on the left-hand side.



Operating Mode Configuration:

The Ethernet communication board has two banks of 8-position DIP switches: SW1 and SW2. The function of these switches is slightly different for a host unit and a remote unit. We recommend powering the unit down while making any changes to the configuration. **SW1 is not used. Make sure all switches are in the open position.**

SW1-	HOST	REMOTE
1		
2		
3		
4		
5		
6		
7		
8		

SW2-	HOST	REMOTE
1	# of Channels on Remote	# of Channels on Remote
2	# of Channels on Remote	# of Channels on Remote
3	# of Channels on Host	
4	# of Channels on Host	
5		
6		
7		
8	Host / Remote Select	Host / Remote Select

Host Configuration:

To make an RCI-200 operate as a host unit, make sure that SW2-8 is closed.

Next, set the **number of channels of the remote** using SW2-1, -2. One channel is considered 1 analog input/output plus 1 contact input/output. Hence an RCI-200 can have at most 2 channels.

SW2-1	SW2-2	Channels on Remote
OPEN	OPEN	1
CLOSED	OPEN	2

Next, set the **number of channels of the host** using SW2-3, -4. An RCI-200 can at most have 2 channels. This is the number of channels that will be exchanged between the host and each remote.

SW2-3	SW2-4	Channels on Host
OPEN	OPEN	1
CLOSED	OPEN	2

Remote Configuration:

To make an RCI-200 operate as a REMOTE unit, make sure that SW1-8 is open.

Next, set the **number of channels on the remote** using SW2-1, -2. One channel is considered 1 analog input/output plus 1 contact input/output. Hence an RCI-200 can have at most 2 channels.

SW2-1	SW2-2	Channels on Remote
OPEN	OPEN	1
CLOSED	OPEN	2

Ethernet Configuration:

The RCI-200-NET uses an embedded Ethernet module called Siteplayer. It is the interface between the RCI and the Ethernet connection. In order to establish a connection between two RCI-200-NET units, the Siteplayer must be configured to the specific network parameters where it is to be deployed. This configuration is done with a web interface on the Siteplayer. Most parameters are factory preset and should not be changed by the user or a loss of connection may result.

In order to gain access to the Siteplayer for the first time when it is connected to a network we suggest using the Rendezvous browser. It is available for download from our website at www.pribusin.com/rci200net.html . Click on the Web Servers service in the left window and you should see your RCI-200-NET units appear in the right window.

To access the Siteplayer web configuration, simply double-click the name in the right window and a browser will open and point to the currently assigned IP address of the Siteplayer. By default the Siteplayer uses DHCP to obtain an IP address on the network. This will have to be changed to a fixed IP address at least on the Remote so that the Host can find it and connect to it.

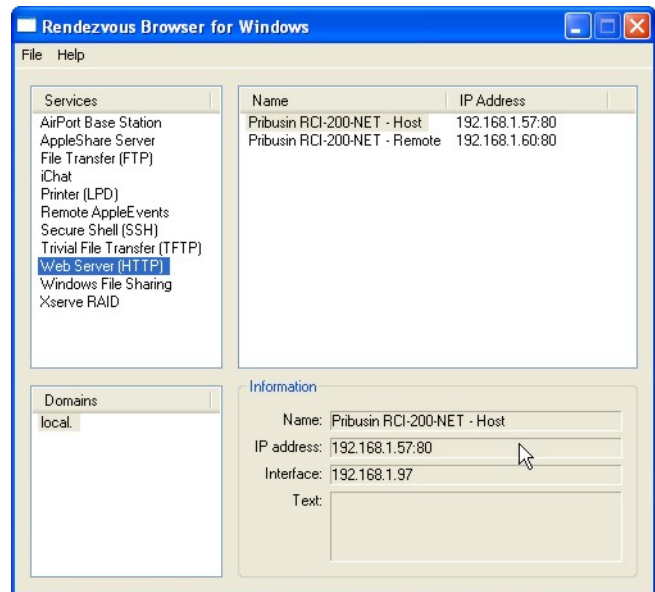

Next, a login window will appear and you need to enter a username and password. Factory defaults are **user** and **password**.

We recommend that these be changed before the system is deployed for final installation.



You should now see the main Siteplayer Home page.

Across the top are several text links that allow access to the various configuration pages.

Following will be a description of these pages.

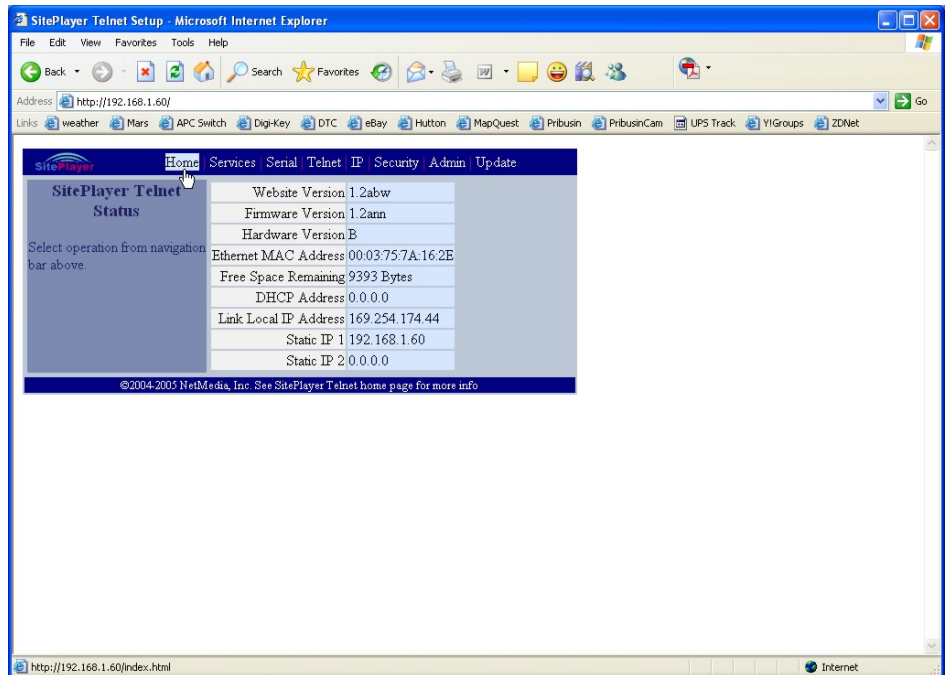

The **Services** page allows the device name to be changed. We recommend you do not interchange the Host and Remote device names. Feel free to change the Host to something like 'Main Street Station – Host'. Keep the words Host and Remote in the device names as they are.

The **Telnet Port** is factory preset to 4000. You may change it but be sure to change it on both the Host and Remote and on the **Services** page and the **Telnet** page.

Leave all other settings as they are shown. Do not enable TCP Keep-Alive as it may interfere in establishing a connection.

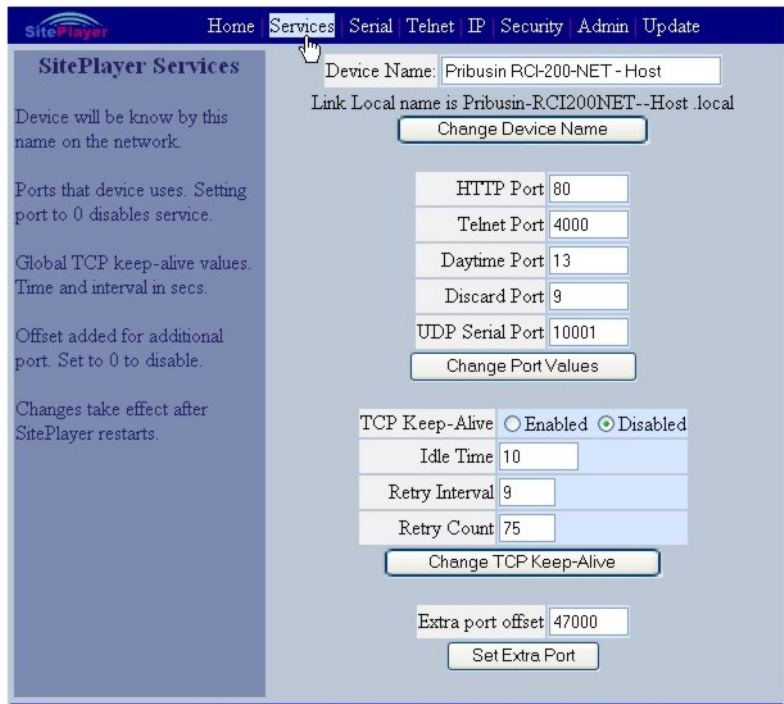

The **Serial** page configures the serial interface settings between the Siteplayer and the RCI-200-NET.

DO NOT MAKE ANY CHANGES TO THIS PAGE.

The **Telnet** page configures the telnet client and server modes. The RCI-200-NET Remote is a Telnet Server and the RCI-200-NET Host is a Telnet Client. The client will attempt to connect to the server and must therefore know the server's IP address.

The server (Remote) must therefore have a fixed IP address. This may be a local IP address such as 192.168.x.x if the units are connected to the same local network. The IP address is configured on the **IP** page.

The client (Host) must be told the IP address of the server in **Remote IP**. After entering the IP address, click the Set 'Telnet Configuration' button and the Siteplayer will restart.

On the **IP Configuration** page, you can assign the fixed IP address for the server (Remote) as well as the Gateway and subnet mask.

Click the 'Set Fixed IPs' button when done. The Siteplayer will restart.

SitePlayer Home Services Serial Telnet **IP** Security Admin Update

IP Configuration

You can enable/disable obtaining a DHCP IP address by (un)checking the box.

You can enable up to two static IP addresses. A nonzero value for the IP address enables it.

Changes take effect after SitePlayer restarts.

DHCP Enabled Disabled

DHCP Address 0.0.0.0

DHCP Gateway 0.0.0.0

DHCP Mask 255.255.255.255

DHCP DNS Server 0.0.0.0

Set DHCP Configuration

Static IP Address #1	192	168	1	57
Static IP Gateway #1	192	168	1	254
Static IP Mask #1	255	255	255	0
Static IP Address #2	0	0	0	0
Static IP Gateway #2	0	0	0	0
Static IP Mask #2	0	0	0	0

Set Fixed IPs

©2004-2005 NetMedia, Inc. See SitePlayer Telnet home page for more info

The **Siteplayer Security** page allows access to the web configuration utility to be restricted. Factory default username and password are: **user** and **password**.

You may also setup authorized IP addresses that may connect to the server (Remote) to further prevent unauthorized access.

SitePlayer Home Services Serial Telnet IP **Security** Admin Update

SitePlayer Security

Specify username and password for web setup page access.

Specify port, IP address and Mask to restrict access of remote computers.

Changes take effect after SitePlayer restarts.

Security Enabled Disabled

New Username user

New Password:

Change Username and Password

Authorized Port Number #1	0			
Authorized IP Address #1	0	0	0	0
Authorized IP Mask #1	0	0	0	0
Authorized Port Number #2	0			
Authorized IP Address #2	0	0	0	0
Authorized IP Mask #2	0	0	0	0
Authorized Port Number #3	0			
Authorized IP Address #3	0	0	0	0
Authorized IP Mask #3	0	0	0	0
Authorized Port Number #4	0			
Authorized IP Address #4	0	0	0	0
Authorized IP Mask #4	0	0	0	0

Modify

The **Administration** page allows for a remote restart of the siteplayer by clicking the 'Restart Siteplayer' button.

The LED parameters have no function.

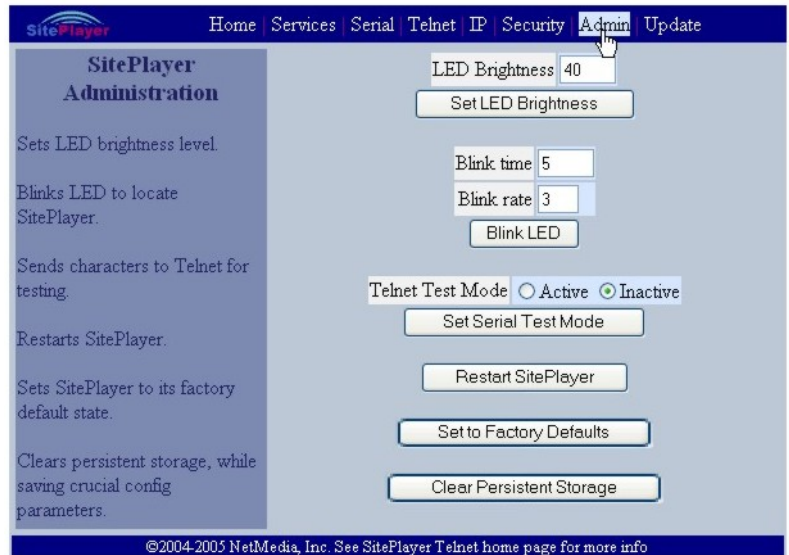

When all parameters have been set correctly and both units are connected to the Ethernet connection, the client (Host) will try to establish a connection with the server (Remote). Once this is accomplished, the yellow Link LED (LD3) will light indicating a connection. At that point the red and green Transmit and receive LEDs should begin flashing alternately on both units.