



*Manufacturers of Process
Controls and Instrumentation*

Instruction Manual

Model: *RCI-400-XXX*

Function: *Remote Control Signal Interface*

Communication: *XXX=SER: RS-232/485*

XXX=MDM Modem Dial-Up

XXX=FSK: Leased Line

XXX=RF9: 900 Mhz Wireless

XXX=RF2: 2.4 Ghz Wireless

Input: 4 "Dry" Contacts and 4 Analog Inputs

Output: 4 Form 'C' Contacts and 4 Analog Outputs

Power: 117VAC, 50/60Hz

24 VDC

Serial #: _____

(If special or required)

For Technical Assistance And Questions Call
USA: (231) 788-2900 CANADA: (905) 660-5336

Restocking Policy

All product returned to Pribusin Inc. in prime condition (not damaged, scratched or defaced in any way) within seven (7) months from the original date of shipment is subject to a 50% restocking charge. All product must be accompanied by a Return Authorization number (RA number) which must be obtained from Pribusin Inc. prior to returning any product.

After seven (7) months from the original date of shipment, products cannot be returned for restocking.

Custom designed products, modified products or all non-standard products may not be returned for restocking.

Warranty Policy

Pribusin Inc. warrants equipment of its own manufacture to be free from defects in material and workmanship, under normal conditions of use and service, and will replace any component found to be defective, on its return to Pribusin Inc., transportation charges prepaid, within one year of its original purchase. Pribusin Inc. will extend the same warranty protection on equipment, peripherals and accessories which is extended to Pribusin Inc. by the original manufacturer. Pribusin Inc. also assumes noliability, expressed or implied, beyond its obligation to prelace any component involved. Such warranty is in lieu of all other warranties, expressed or implied.

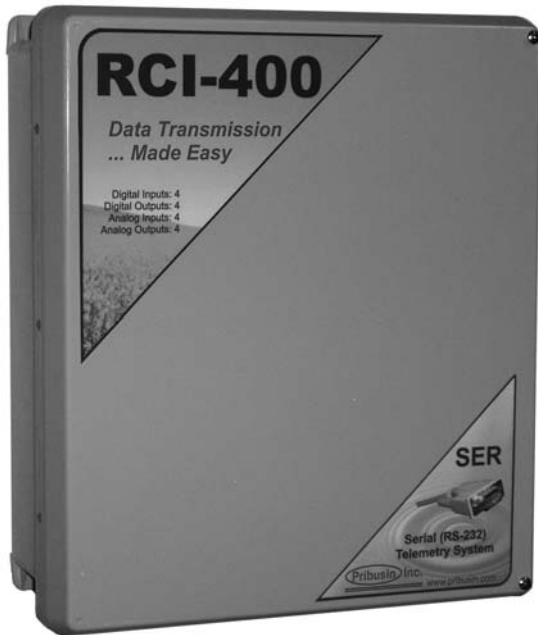

Standard Features:

Bi-directional Communication using a RS232/485 Serial Bus Link

4 Dry Contact and 4 Analog Inputs

4 'C' Relay Contacts and 4 Analog Outputs

No Calibration Required

Microprocessor Controlled for High Accuracy

Power: 117 VAC 50/60 Hz (Optional 24 VDC)

High Noise Rejection



Function:

The RCI-400-SER is a bi-directional remote communication system that exchanges the status of 4 dry contact inputs and 4 analog inputs between a master and remote unit or a PC. A basic system consists of A) one master station and one remote station each with 4 dry contact and 4 analog inputs and 4 'C' relay contact and analog outputs **OR** B) several remote stations and one PC.

In system A), the master unit can interrogate a remote.

In system B), a PC interrogate call several remote units.

LabVIEW drivers are provided for user software development on Pc's.

Connection:

Units are connected via a class 'C' line (Dial-up or leased). Regular J11 Phone Jacks make for easy installation. When connecting units on a PBX system make sure it can accept analog modem transmissions. Serial systems connect via standard modem cable.

Specifications:

Transmission Medium: RS232/485

BAUD Rate: 2400 BAUD typ., 9600, 14.4K available

Operating Temperature: -20 Deg.C. to +50 Deg.C.

Relay Contacts: 10A 1/8Hp @ 125VAC

6A 1/8Hp @ 277VAC

Power: 117 VAC, 60/50 Hz

(24VDC Available)

Enclosure: NEMA4X (NEMA12 available as an option)

Approvals: ETL 3118354:

UL 60950-1-2007; CSA-C22.2 No. 60950-1-07

RCI-400-SER

Enclosures & Dimensions:

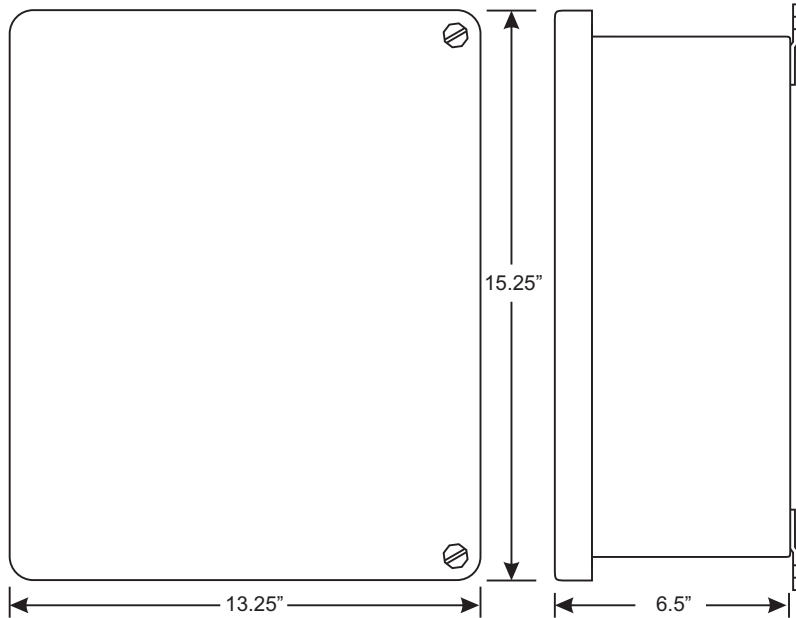

Connection:

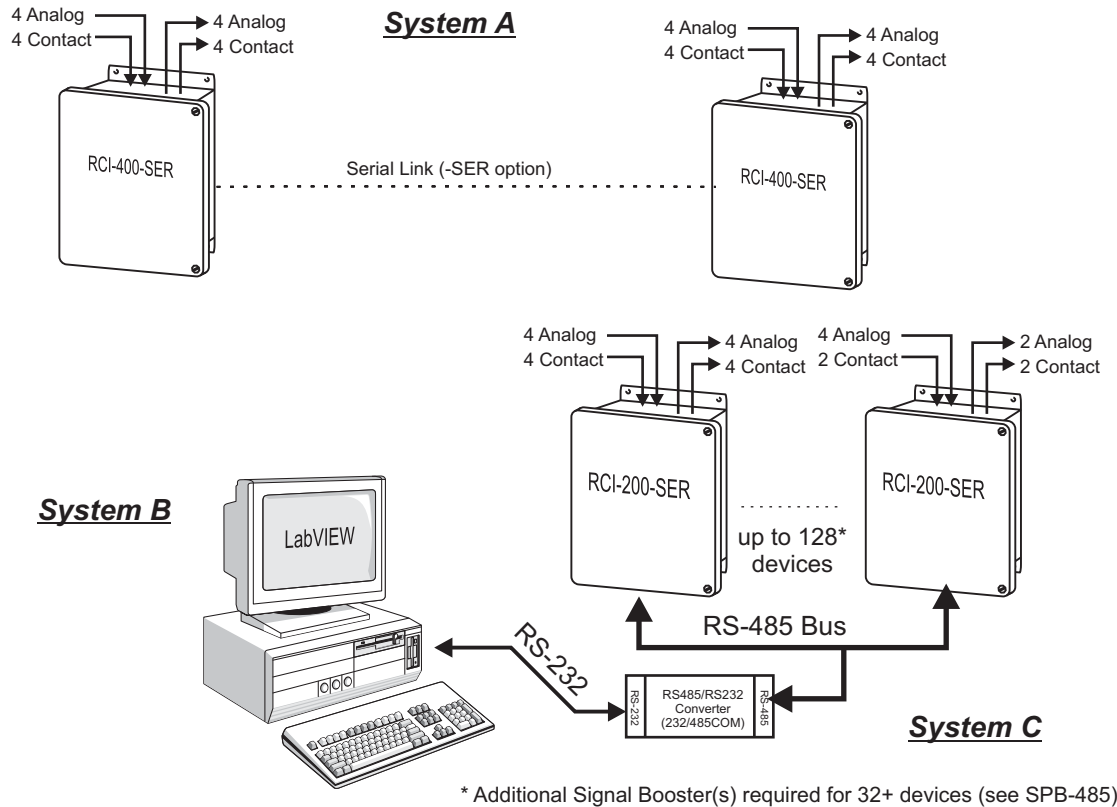

Manufactured By:

Pribusin Inc.

www.pribusin.com
info@pribusin.com

USA:

Pribusin Inc.
 743 Marquette Ave.
 Muskegon, MI 49442
 Ph: (231) 788-2900
 Fx: (231) 788-2929



CANADA:

Pribusin Inc.
 101 Freshway Dr. Unit 57
 Concord, Ontario, L4K 1R9
 Ph: (905) 660-5336
 Fx: (905) 660-4068

Mounting Holes
10

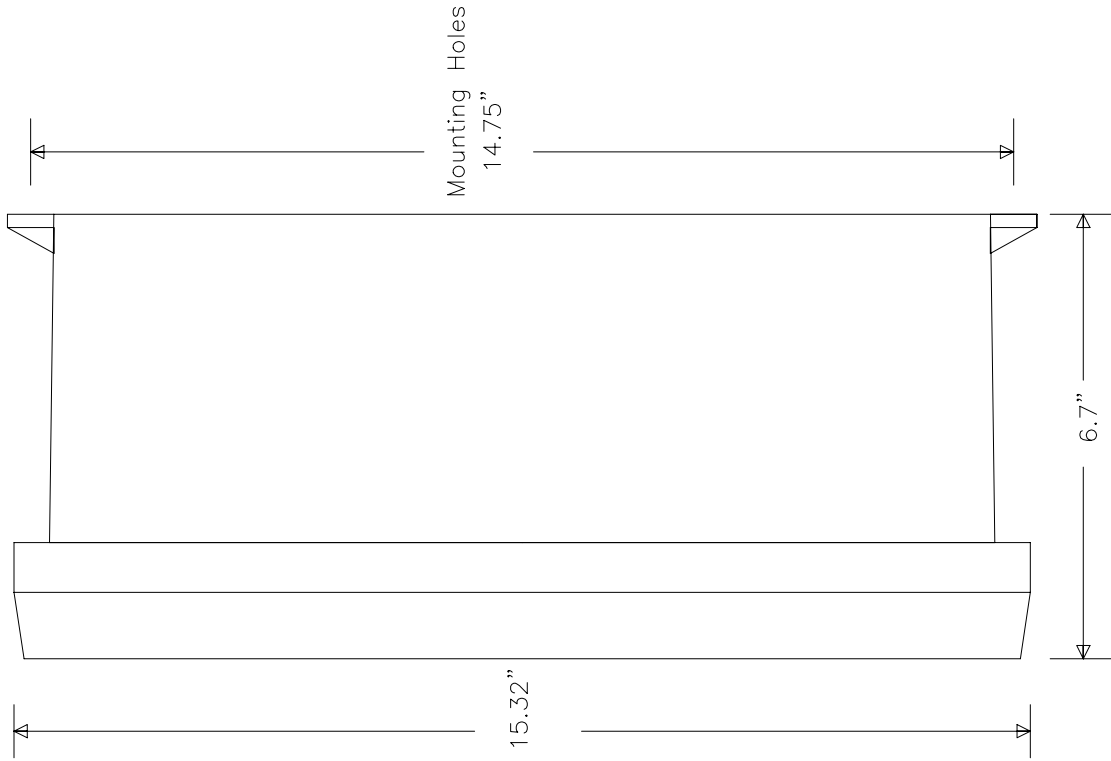
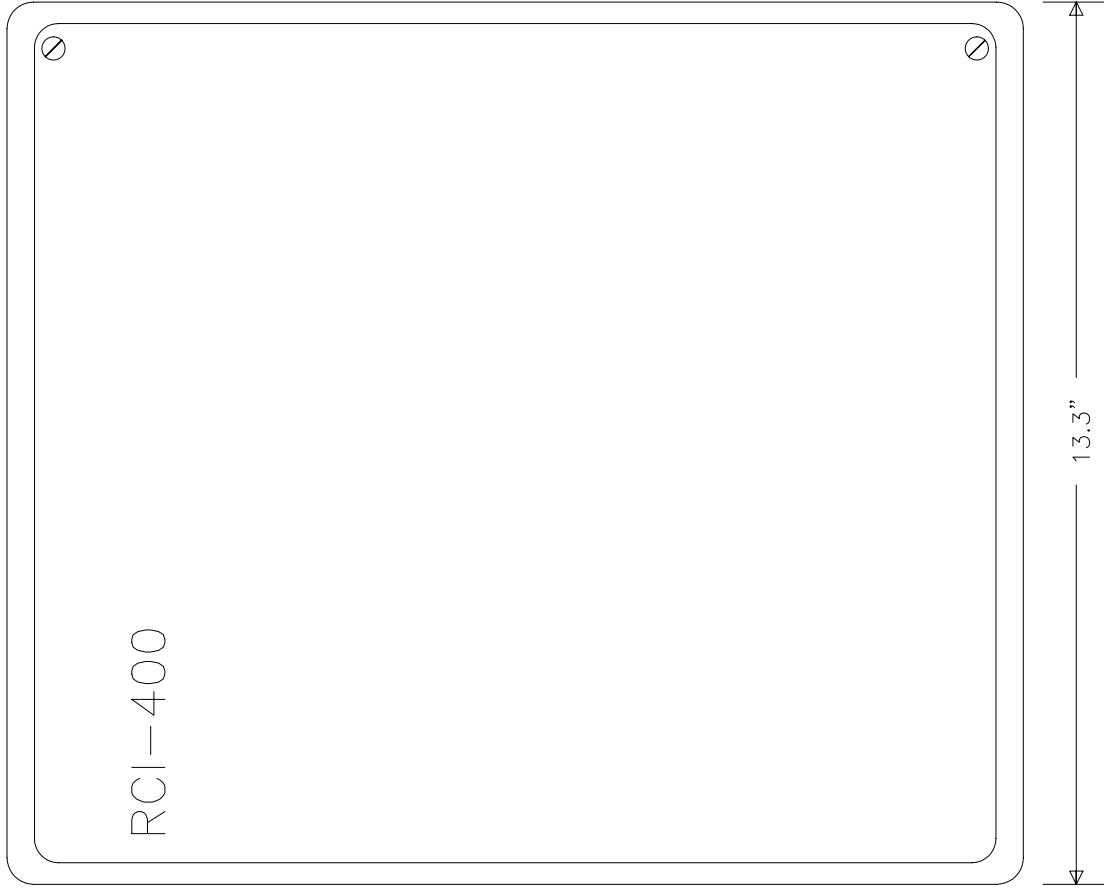

Pribusin Inc. ©	
CHKD: V.B	DATE: MAY14/10
RCI-400 ENCLOSURE DIMENSION	
DWG. NO.: 108126	REV. A

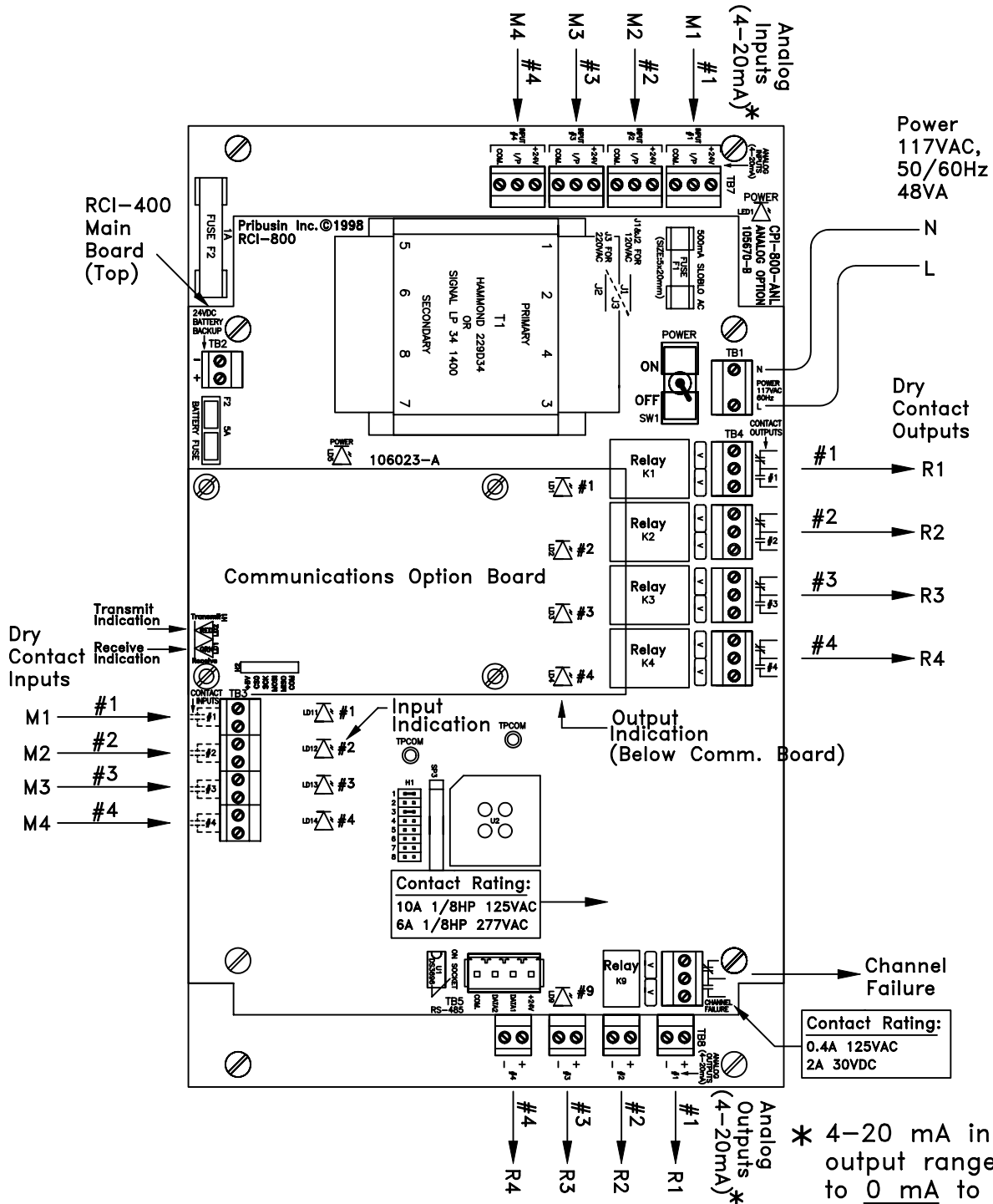

Pribusin Inc. ©		
CHKD:	DATE: Jan 4/01	DRN: MG
Model: RCI-400-XXX Remote Control Signal Interface Connection Diagram		
DWG. NO.:	106411	REV. A

RCI-400 Connections:

The RCI-400 is the main board of an RCI-400-XXX Telemetry system. It provides the input and output signal connections as well as the power supply for the unit. The RCI-400 consists of two circuit boards: a main controller board with four contact inputs and four contact outputs and below it an analog input/output board with four analog inputs and four analog outputs. A separate communications board is added to the RCI-400 to allow it to communicate with other units. This communications board may have its own configuration that is in a separate section of this manual. The following configuration applies only to the RCI-400 board and is common to all communications interfaces.

AC Power & Fuse:

The RCI-400 is typically powered from 120VAC and protected by a 500mA SLOBLO fuse. It can be wired for 240VAC operation by removing (desoldering) power jumpers J1 & J2 and installing (soldering) jumper J3.

When changing the RCI-400 to 240VAC power make sure to change the fuse to half of its value, 250mA. This is important since at 240VAC the RCI-400 requires only half the current as if it were powered from 120VAC. Proper protection is only achieved by reducing the fuse value as mentioned above.

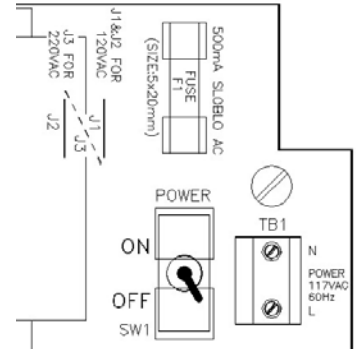

DC Power & Battery Backup:

The RCI-400 may also be powered from a 24VDC source which could be a battery or a DC power supply. The 24VDC power input is polarity protected with a fuse to prevent damage to the RCI-400 by inadvertent reverse polarity. A DC fuse provision is also provided if this power option is utilized. Insert a 5A automotive type blade fuse into the Battery Fuse socket.

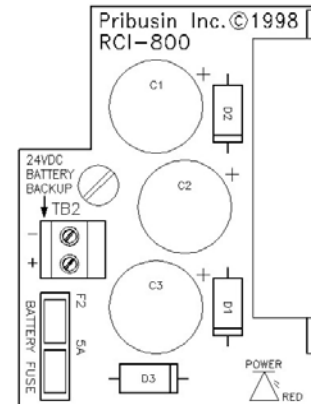

A separate 1A fuse protects the 24VDC power output to field transmitters (+24V terminal on analog inputs). This fuse is located on the analog input output board (bottom board).

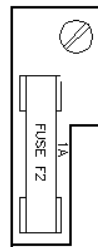

Inputs:

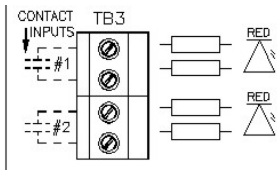

The RCI-400 has four dry contact inputs and 400 0-20mA inputs. The dry contact inputs are excited with 24VDC and will source approximately 20mA when the contact is closed. A red LED lights up when a contact input is closed.

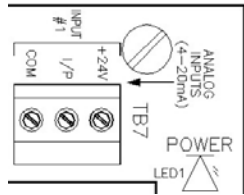

The analog inputs are configured as 0-20mA inputs and have a 250Ω input impedance. Each input terminal has three connections: +24V, I/P, COM. The +24V power output may be used to power field transmitters. Up to 125mA may be used to power a transmitter. The input signal is connected to I/P(+) and COM(-).

Analog inputs are connected to the RCI-400 in two fashions: 1) Normal (3-wire connection) or 2) two-wire connection. On a 3-wire connected input, an external power supply or the +24V power output terminal of the RCI provides power to the field transmitter. The field transmitter has a current source that provides the 4-20mA signal back to the RCI-400. If using the power supply of the RCI-400, the field transmitter may draw up to 125mA. A total of 1A is available to power up to 8 field transmitters.

On a 2-wire connected input, the field transmitter receives power from the RCI-400 and superimposes the signal onto the power return path. A maximum of 20mA will flow in such a connection. Make sure to consult the field transmitter manual to determine how to connect it to the RCI-400.

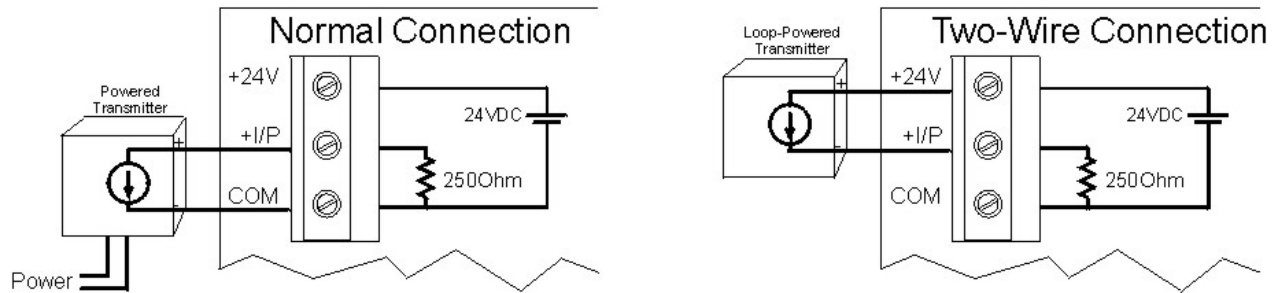

Outputs:

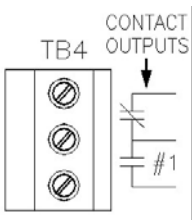

The RCI-400 has 400 form 'C' relay contact outputs and 400 0-20mA analog outputs. The relay contacts are capable of switching 120VAC, 10A or 240VAC, 6A. An energy absorbing varistor is installed across each contact to limit switching transients. A ninth relay contact acts as a communications fail indicator. If no communication occurred within 60 seconds, this relay contact will energize. Upon re-established communication this relay will de-energize again.

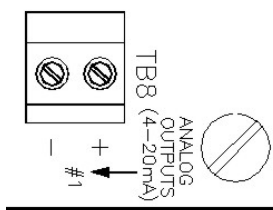

The 400 analog outputs are typically configured as 0-20mA outputs and can drive into a 1000Ω load each, provided that the power supply to the unit is not below 24VDC. The outputs are not isolated from each other or from the inputs. Care must be taken when connecting the outputs to different devices so that no inadvertent ground loops are established.

Output Calibration & Input Testing:

The outputs on the RCI-400 are factory calibrated and should not require any adjustments. To check the calibration of the outputs and relays use jumpers H1-7 & H1-8 as shown below to set them to known states. If an output should require some adjustment, the main circuit board has to be removed from the analog input/output board to gain access to the output calibration potentiometers. **With the power off**, remove the main circuit board and set it aside leaving it connected to the analog input/output board via the 4-conductor I/O cable. Turn the power on and insert jumper H1-8 on the main circuit board and turn the OUTPUT CALIB. trim pot for a particular output until that output reads 20mA. Turn the power off again before re-assembling the unit.

H1-7	H1-8	Function
OUT	OUT	Normal Operation
OUT	IN	Outputs=20mA, Relays=Energized
IN	OUT	Outputs=0mA, Relays=De-energized
IN	IN	Outputs=Inputs, Relays=Contact Inputs

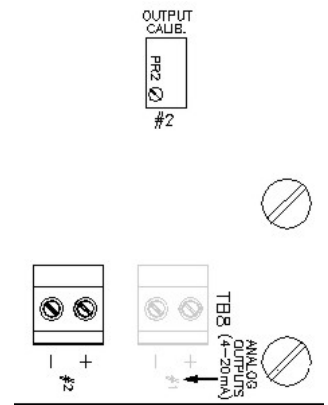

If both jumpers are IN the analog and contact inputs are passed straight through to the analog and relay outputs. This may help in troubleshooting input and output signals.

Make sure both jumpers are removed before resuming normal operation.

RCI-400 Configuration:

The RCI-400 requires no configuration other than for its communication fail operation. In the event of a communications failure on the communications board, the RCI-400 can be set up to take various actions on its outputs. This may be desirable in order to place connected devices into a safe operating mode. By default factory setting, all outputs remain at their last known state if a communications failure occurs.

H1-	Function	OUT	IN
1	Relay Fail Mode	No Change	See H1-2
2	Relay Fail Status	De-Energize	Energize
3	Output Fail Mode	No Change	See H1-4 ¹⁾
4	Output Fail Status	Ramp to 0%	Ramp to 100%
5	Output 0% Value ²⁾	0mA	4mA
6	Output Ramp Rate	10 seconds	60 seconds
7	I/O Calibration		
8	I/O Calibration		

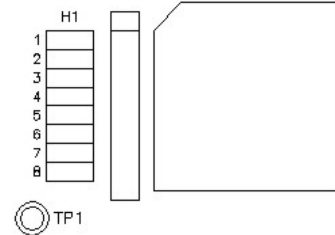

- 1) If H1-3=IN then all analog outputs will ramp to the either 0% or 100% depending on jumper H1-4. The outputs will change at a rate determined by the jumper H1-6.
- 2) The low end of the output value can be selected to be either 0mA or 4ma depending on jumper H1-5. This setting only applies to the output value during a fail condition when the outputs are selected to ramp to 0%. If jumper H1-5 is out, the outputs will ramp to 0mA, if it is in they will ramp to 4mA. The setting of this jumper does not affect the outputs during normal operation.

SERIAL Communication Option:

The -SER communications option for the RCI series utilizes either an RS-232 or RS-485 link to exchange the signal data between a host and its remote(s). There are three types of **Topologies** that can be configured: 1) Point-to-Point, 2) Host-to-Multipoint and 3) PC-to-Multipoint

In a **Point-to-Point** topology one host communicates with one remote. The two exchange all their signals with one another. The remote is configured as remote #1 even though it is the only remote in the system.

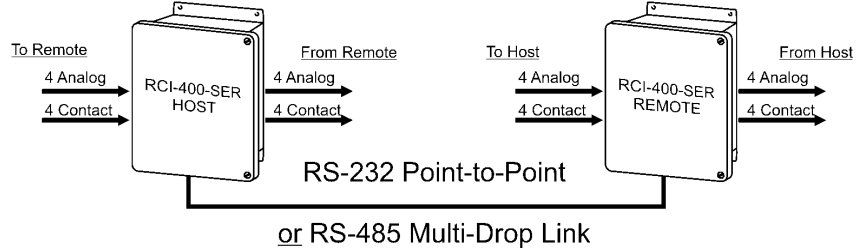

In a **Host-to-Multipoint** topology one host communicates to several remotes. Each remote is assigned an address (1,2,3, etc.) so that the host may distinguish between them. There may at most be as many remotes as there are inputs & outputs on the host.

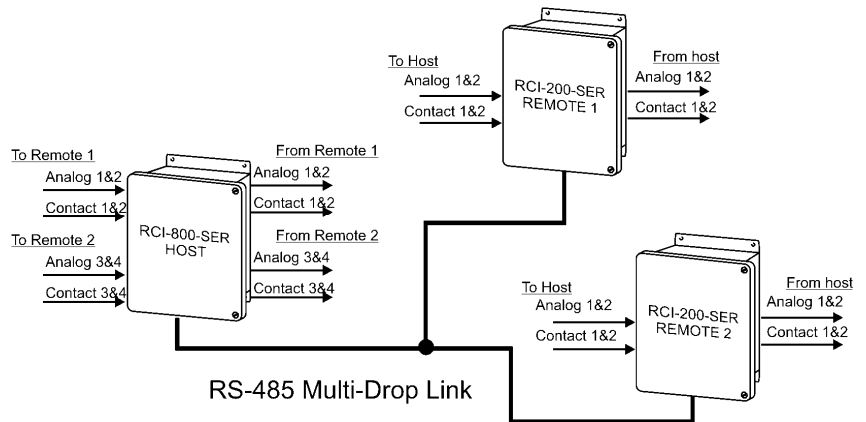

For example, an RCI-400 system, having 400 analog/contact inputs and outputs, may communicate with up to 400 remotes each having one analog/contact input and output. In this case all **#1 inputs and outputs on the host correspond to the #1 inputs and outputs on remote #1** and all **#2 inputs and outputs on the host correspond to the #1 inputs and outputs on remote #2** and so on

In a **PC-to-Multipoint** topology one PC (or PLC) host communicates with one or more remotes via MODBUS ASCII protocol. Software that runs on the PC (or PLC) takes the place of the Host and can directly read and write the inputs and outputs of the remote units. Each remote is assigned an address (1,2,3, etc.) so that the host may distinguish between them.

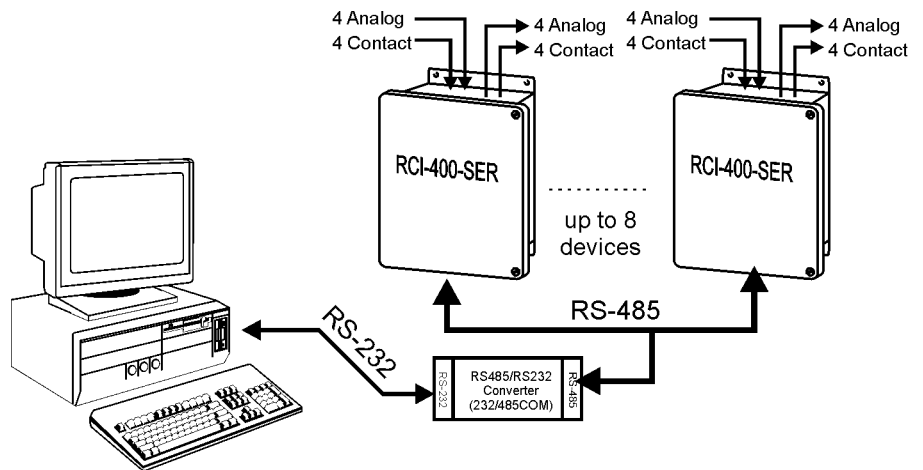

SERIAL Configuration:

All SERIAL configurations are done via two banks of DIP switches SW1 and SW2. The switches are located on the communications board just above the main circuit board. They are a slide switch type that slides **up for ON** and **down for OFF** if viewed straight-on with the RCI mounted upright on a wall.

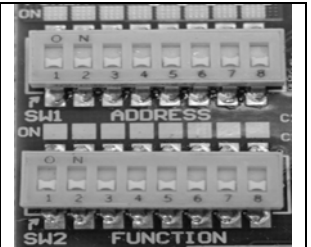

SW1-	HOST	REMOTE
1	# of Remotes	Remote Address
2	# of Remotes	Remote Address
3	# of Remotes	Remote Address
4	Reply Timeout	
5	Comm. Interval	Comm. Interval
6	Comm. Interval	Comm. Interval
7	Baud Rate	Baud Rate
8	Baud rate	Baud rate

SW2-	HOST	REMOTE
1	# of Channels on each Remote	# of Channels on each Remote
2	# of Channels on each Remote	# of Channels on each Remote
3	# of Channels on Host	
4	# of Channels on Host	
5		
6		
7		
8	Host / Remote Select	Host / Remote Select

SW3 on the communications board must be set to the **RCI I/O** position (switch lever moved to the right) at all times. This can be done at any time without turning off the main power.

Handshake lines CTS/DSR (JP3) & RTS/DTR (JP2) are generally not implemented but are available for special applications. Consult factory for more details.

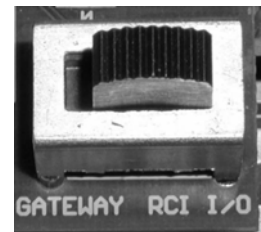

Common Configuration (applies to Host & Remote):

Baud Rate: The communication baud rate of the RCI-XXX-SER is selectable with SW1-7 &-8. Both the host and remote must be set to the same setting.

SW1-7	SW1-8	BAUD Rate
OFF	OFF	1200
ON	OFF	2400
OFF	ON	9600
ON	ON	19200

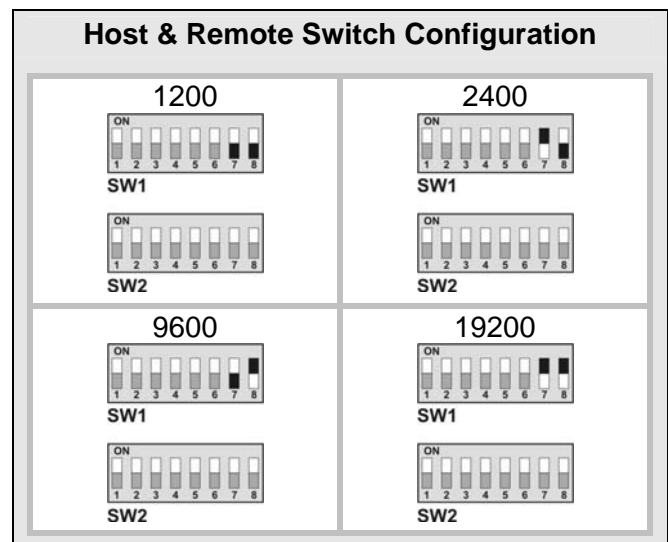

Communication Interval: The communication interval of the RCI-XXX-SER is selectable with SW1-5 &-6. Both the host and remote must be set to the same setting.

SW1-5	SW1-6	Comm. Interval
OFF	OFF	1 sec
ON	OFF	1 min
OFF	ON	10 min
ON	ON	15 min

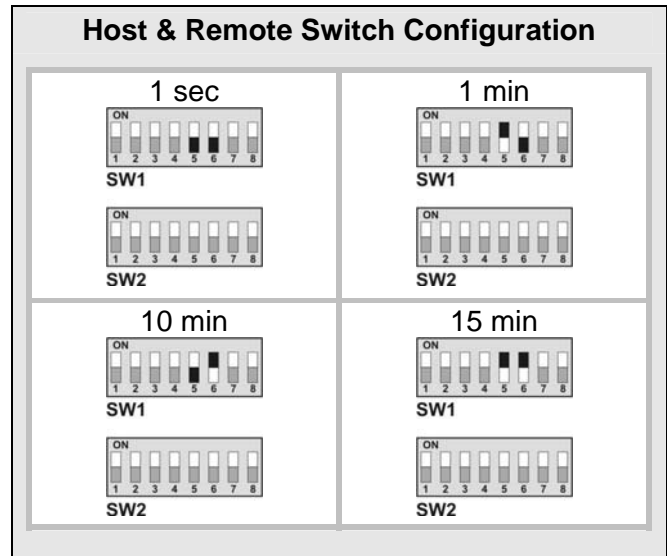

Host Configuration:

To make an RCI-400 operate as a host unit, make sure that SW2-8 is flipped to the ON position.

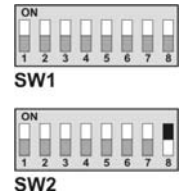

Next, set the **number of remotes** that the host is to communicate with using SW1-1, -2 & -3. These switches are binary encoded as shown in the chart below.

SW1-1	SW1-2	SW1-3	# of Remotes
OFF	OFF	OFF	1
ON	OFF	OFF	2
OFF	ON	OFF	3
ON	ON	OFF	4

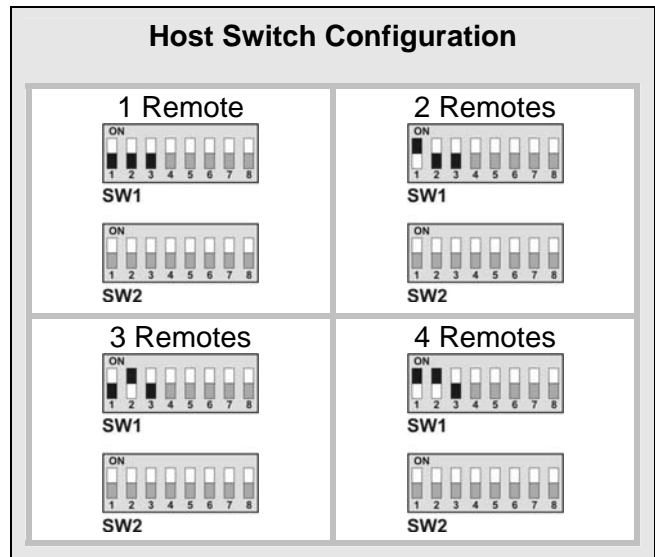

The host must know the number of channels that the remotes are configured for. Next, set the **number of channels of each remote** using SW2-1 & -2. One channel is considered 1 analog input/output plus 1 contact input/output. Hence an RCI-400 can have at most 4 channels.

SW2-1	SW2-2	Channels on Remotes
OFF	OFF	1
ON	OFF	2
OFF	ON	4

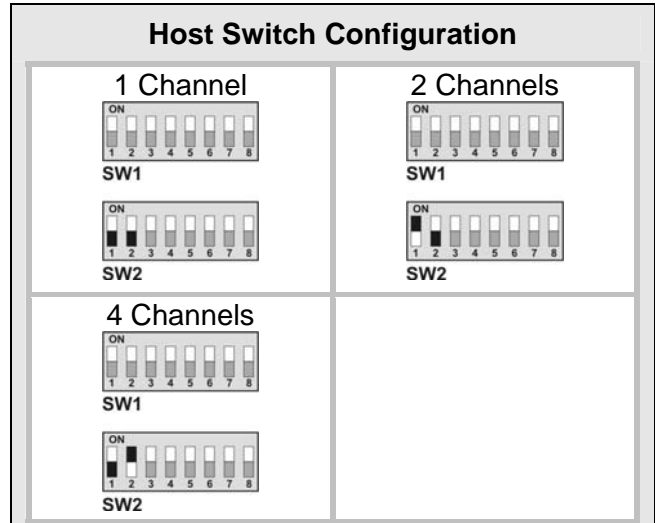

Next, set the **TOTAL number of channels of the host** using SW2-3, -4. An RCI-400 can at most have 4 channels. This is the number of channels that will be exchanged between the host and each remote.

SW2-3	SW2-4	Channels on Host
OFF	OFF	1
ON	OFF	2
OFF	ON	4

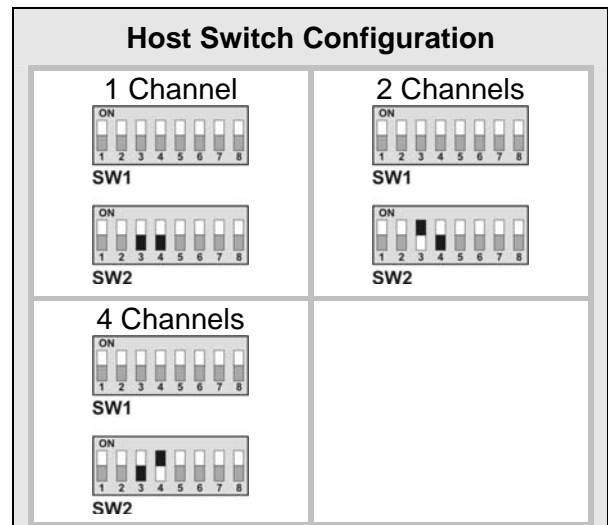

An optional **Reply Timeout** parameter can be set on the host only using SW1-4. An RCI host operating in a system that has a long delay in transmission may experience a longer than normal (1s) communication reply from the remote(s). This parameter tells the host to extend the reply timeout from 1 second to 10 seconds when turned ON.

SW1-4	Reply Timeout
OFF	1 sec
ON	10 sec

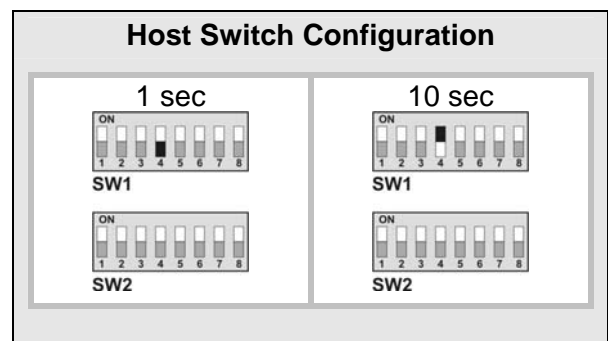

Remote Configuration:

To make an RCI-400 operate as a REMOTE unit, make sure that SW2-8 is flipped to the OFF position.



SW1



SW2

Next, set the **remote address** using SW1-1, -2, & -3. This switch is binary encoded and you will have to convert the remote address to binary first.

SW1-1	SW1-2	SW1-3	Remote Address
OFF	OFF	OFF	1
ON	OFF	OFF	2
OFF	ON	OFF	3
ON	ON	OFF	4
OFF	OFF	ON	5
ON	OFF	ON	6
OFF	ON	ON	7
ON	ON	ON	8

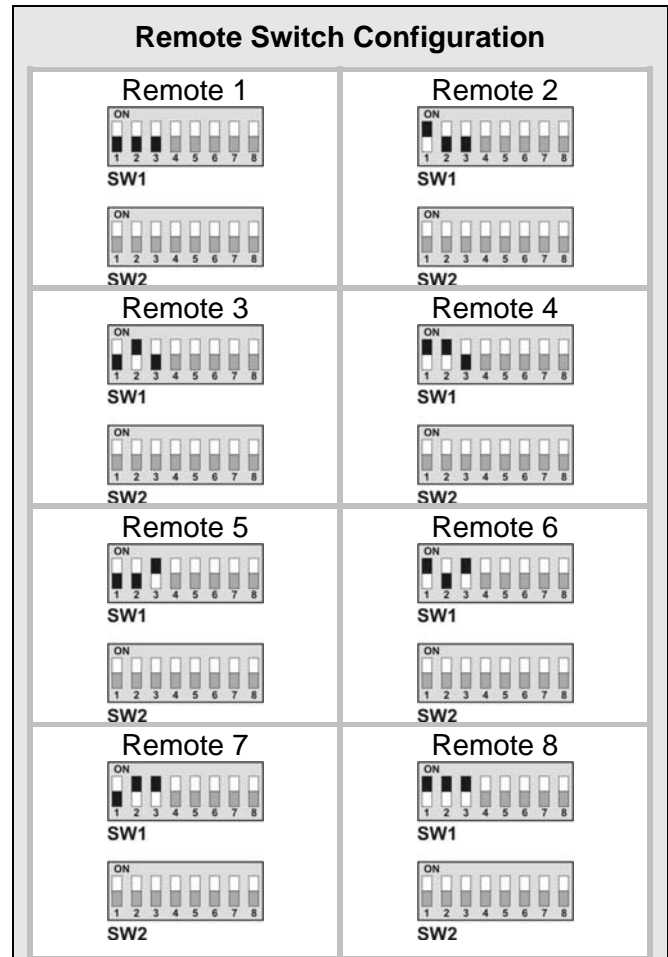

Next, set the **number of channels on this remote** using SW2-1, -2. One channel is considered 1 analog input/output plus 1 contact input/output. Hence an RCI-400 can have at most 4 channels.

SW2-1	SW2-2	Channels on Remotes
OFF	OFF	1
ON	OFF	2
OFF	ON	4

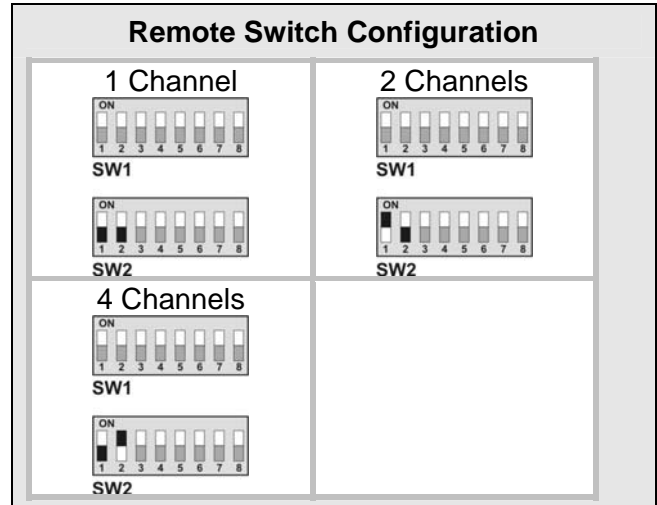

PC or PLC Interfacing using MODBUS ASCII:

The RCI-400-SER can communicate directly to a PC or PLC using MODBUS ASCII protocol. Numerous off-the-shelf software packages have built-in MODBUS support. The following information provides the MODBUS specific parameters necessary to configure the PC/PLC software.

Message Format

<i>Speed</i>	<i>Start</i>	<i>Data</i>	<i>Parity</i>	<i>Stop</i>
9600 ¹⁾	1	7	E	1

¹⁾ default setting

ASCII Framing

<i>Start</i>	<i>Address</i>	<i>Function</i>	<i>Data</i>	<i>LRC</i>	<i>End</i>
1 Char :	2 Chars	2 Chars	n Chars	2 Chars	2 Chars CR,LF

MODBUS Registers

The functions and registers listed in the table below are the only ones implemented on all RCI products at this time.

Description (Function)	RCI-100-XXX	RCI-200-XXX	RCI-400-XXX	RCI-400-XXX
Read Relay Status (01)	00001	00001-00002	00001-00004	00001-00008
Read Digital Input (02)	10001	10001-10002	10001-10004	10001-10008
Read Analog Output (03)	40001	40001-40002	40001-40004	40001-40008
Read Analog Input (04)	30001	30001-30002	30001-30004	30001-30008
Set Relay Status (05)	00001	00001-00002	00001-00004	00001-00008
Set Analog Output (06)	40001	40001-40002	40001-40004	40001-40008
Set Multiple Relays (0F)	00001	00001-00002	00001-00004	00001-00008
Set Multiple Analog Out (10)	40001	40001-40002	40001-40004	40001-40008