

*Manufacturers of Process  
Controls and Instrumentation*

# ***Instruction Manual***

Model: *UA-7D-TXX-DIF*

Function: Differential T/C Alarm Trip

Input Range:

- X= : 0-30 Deg. F. Type \_\_\_\_\_
- X= : 0-40 Deg. F. Type \_\_\_\_\_
- X= : 0-50 Deg. F. Type \_\_\_\_\_
- X= : 0-75 Deg. F. Type \_\_\_\_\_
- X= : 0-100 Deg. F. Type \_\_\_\_\_
- X= : 0-150 Deg. F. Type \_\_\_\_\_
- X= : 0-200 Deg. F. Type \_\_\_\_\_
- X= : 0-320 Deg. F. Type \_\_\_\_\_
- X= : \_\_\_\_\_

Output:  Two Form "C" Contacts

- Power:
- 117VAC, 50/60 Hz
  - 24 VDC, 160 mA
  - \_\_\_\_\_

Serial #: \_\_\_\_\_ (If special or required)

For Technical Assistance And Questions Call  
USA: (734) 677-0459 CANADA: (905) 660-5336

## Restocking Policy

**All product returned to Pribusin Inc. in prime condition (not damaged, scratched or defaced in any way) within seven (7) months from the original date of shipment is subject to a 50% restocking charge. All product must be accompanied by a Return Authorization number (RA number) which must be obtained from Pribusin Inc. prior to returning any product.**

**After seven (7) months from the original date of shipment, products cannot be returned for restocking.**

**Custom designed products, modified products or all non-standard products may not be returned for restocking.**

## Warranty Policy

**Pribusin Inc. warrants equipment of its own manufacture to be free from defects in material and workmanship, under normal conditions of use and service, and will replace any component found to be defective, on its return to Pribusin Inc., transportation charges prepaid, within one year of its original purchase. Pribusin Inc. will extend the same warranty protection on equipment, peripherals and accessories which is extended to Pribusin Inc. by the original manufacturer. Pribusin Inc. also assumes noliability, expressed or implied, beyond its obligation to prelace any component involved. Such warranty is in lieu of all other warranties, expressed or implied.**



### Standard Features:

All Standard T/C Input Types

Many Standard Temperature Ranges (Special Ranges Available)

2 Form 'C' Relay Contact Outputs

Each Relay Contact has Individual Setpoint, Deadband and Delay Adjustment.

Easy Field Calibration (Typ. calibration time < 2 min. using handheld meter only)

Microprocessor Controlled for High Accuracy

Power: 117 VAC 50/60 Hz (Optional 24 VDC)

High Noise Rejection

CSA and NRTL Approved (LR 51078)

### Function:

The UA-7D-TXX is a microprocessor controlled Thermocouple alarm trip. It is easily field configurable to operate in a large number of different modes. Each relay contact output is individually configurable to the following modes of operation: High/Low Trip, Normally Energized / De-energized. Additionally, both relays operate from the same input to give two levels of alarm for a single input.

A delay feature allows a 0-60 sec. adjustable ON delay to be added to the trip function in order to screen out intermittent and erroneous alarms. If the delay function is activated, the input must be greater than the setpoint for the time specified by the delay before the relay will activate. There is also a combined ON and OFF delay function which, in addition to delaying the relay 'turn-on' time, delays the relay 'turn-off' time.

### Calibration:

Each relay contact has three potentiometers that are used to adjust the setpoint, deadband and delay settings. The setpoint and deadband can be set anywhere from 0-100% of the input range. The delay is adjustable from 0-60 sec. A test point next to each potentiometer shows a voltage of 0-5 VDC for a setting of 0-100%.

### Specifications:

Accuracy/Linearity: +/- 0.3% max., +/- 0.1% typ.  
Operating Temperature: -40 Deg.C. to +50 Deg.C.  
Temperature Effects: +/-0.5% max., +/-0.2% typ.  
(for 40 Deg.C. change)  
Contact Rating: 10A 1/8Hp @ 125VAC  
6A 1/8Hp @ 277VAC

# UA-7D-TXX

## Enclosures & Dimensions:

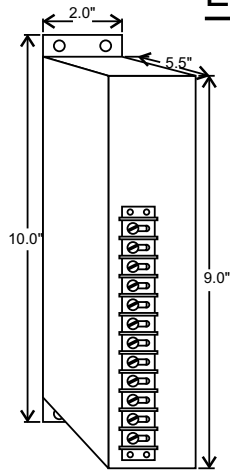

Standard Metal Enclosure

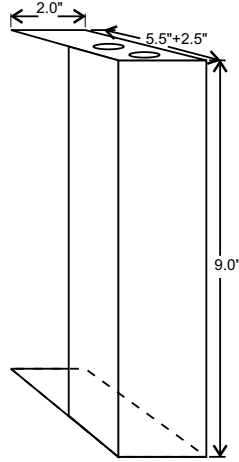

Conduit Cover Option for Metal Enclosure

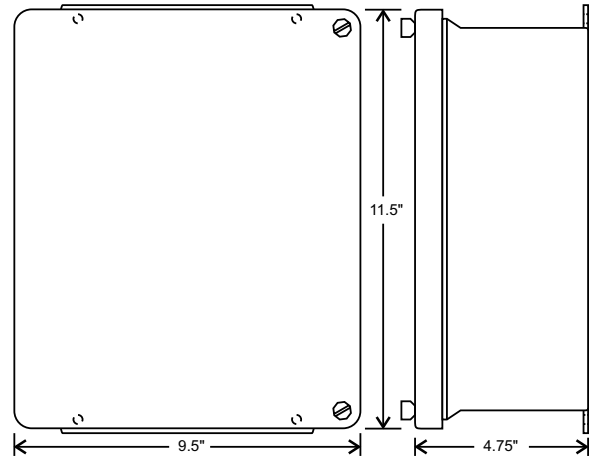

NEMA 4X Option

## Connection:

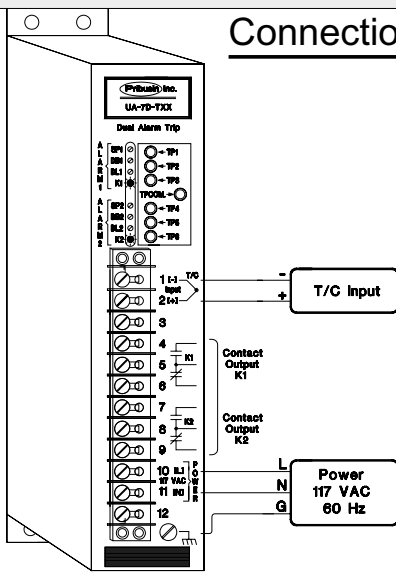

## Model Designation:

Example: A Dual Alarm Trip for a type 'K' thermocouple input over a range of 0-500 F is designated by: UA-7D-TK2

Range	J	K	E	T	R	S
0 to 300F -18 to 150C	TJ1		TE1	TT1		
0 to 400F -18 to 204C	TJ2	TK1	TE2	TT2		
0 to 500F -18 to 260C	TJ3	TK2	TE3	TT3		
0 to 750F -18 to 400C	TJ4	TK3	TE4		TR1	TS1
0 to 1000F -18 to 538C	TJ5	TK4			TR2	TS2
0 to 1500F -18 to 816C		TK5			TR3	TS3
0 to 2000F -18 to 1093C		TK6			TR4	TS4
0 to 3200F -18 to 1760C					TR5	TS5
-350 to 1100F -200 to 600C	TJ6	TK7	TE5			

## Options: (Add to end of Model Number)

- A - 24 VDC Prime Power
- B - 240 VAC Prime Power (not CSA approved)
- T - 200 mA Two Wire Supply (24 VDC unreg.)
- C - Conduit Cover for Metal Enclosure (above)
- N - NEMA 4X enclosure (see above)

Manufactured By:

**Pribusin Inc.**

[www.pribusin.com](http://www.pribusin.com)  
[info@pribusin.com](mailto:info@pribusin.com)

### USA:

Pribusin Inc.  
3938 Trade Center Drive  
Ann Arbor, MI 48108-2072  
Ph: (734) 677-0459  
Fx: (734) 677-0861



### CANADA:

Pribusin Inc.  
101 Freshway Dr. Unit 57  
Concord, Ontario, L4K 1R9  
Ph: (905) 660-5336  
Fx: (905) 660-4068

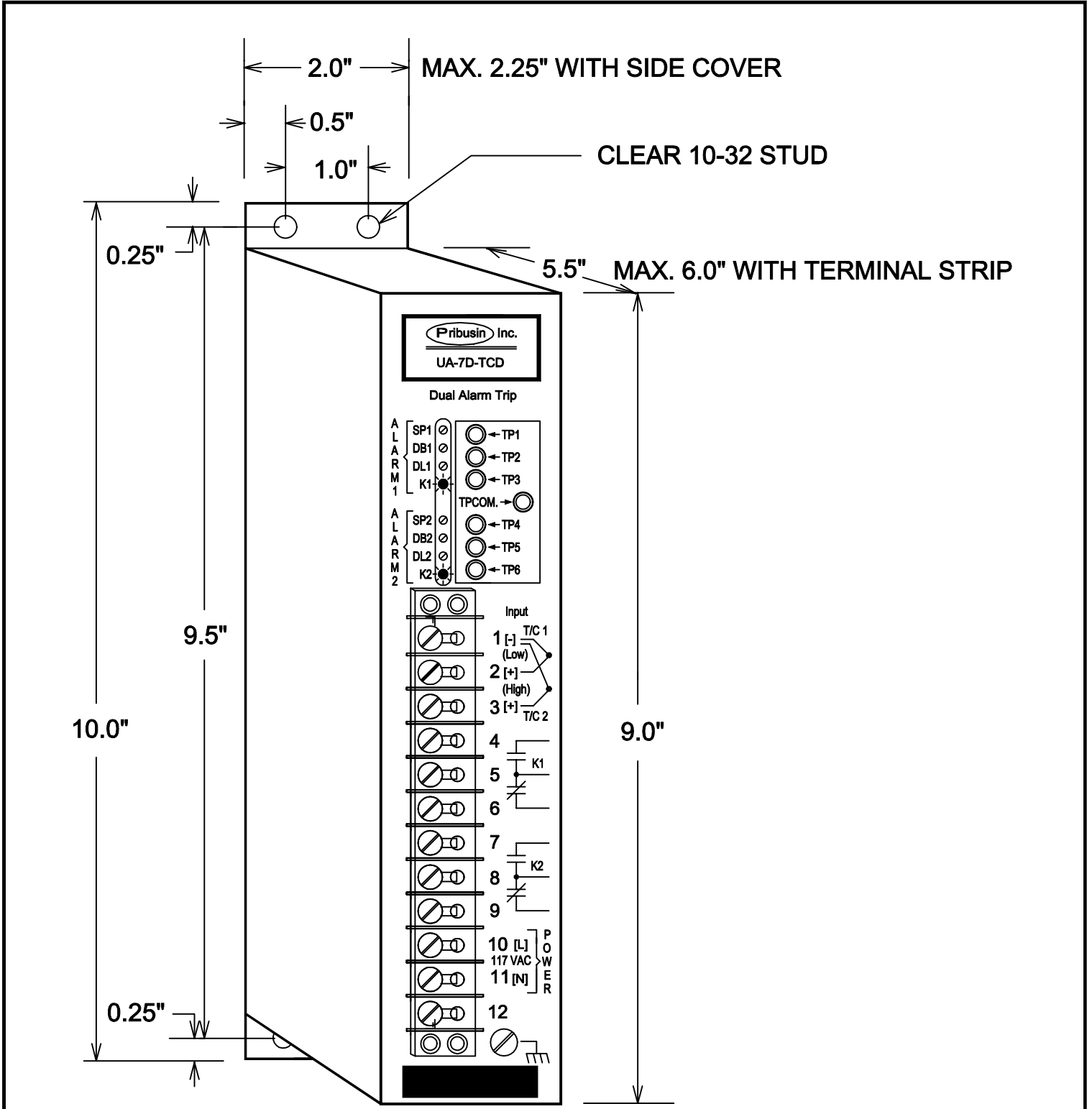

<b>Pribusin Inc. ©</b>		
CHKD:	DATE: AUG. 12/93	DRN: KS
<b>Model: UA-7D-TCD</b> <b>Dual Alarm Trip</b> <b>Enclosure Drawing</b>		
DWG. NO.:	104489	REV. A

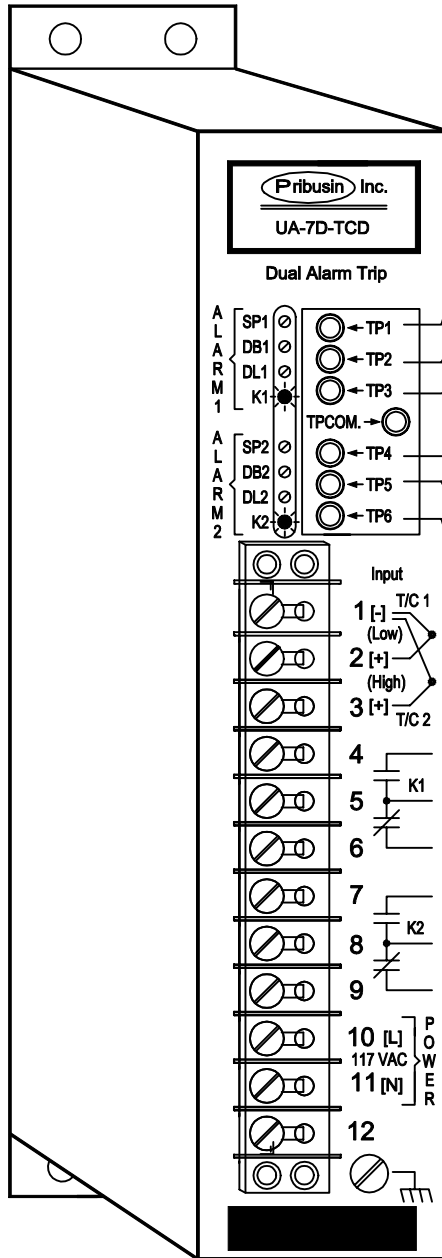

Place meter on TP1 to TPCOM, set setpoint to value required. 0 to 5 VDC represents 0 to 100%.

Place meter on TP2 to TPCOM, set deadband to value required. 0 to 5 VDC represents 0 to 100%.

Place meter on TP3 to TPCOM, set delay to value required. 0 to 5 VDC represents 0 to 1 minute.

Place meter on TP4 to TPCOM, set setpoint to value required. 0 to 5 VDC represents 0 to 100%.

Place meter on TP5 to TPCOM, set deadband to value required. 0 to 5 VDC represents 0 to 100%.

Place meter on TP6 to TPCOM, set delay to value required. 0 to 5 VDC represents 0 to 1 minute.

CALIBRATION OF RELAY K1

CALIBRATION OF RELAY K2

**NOTE: See Drawing No. 104490-1 for HIGH/LOW TRIP and Relay Energized/De-Energized Jumper settings.**

**Pribusin Inc. ©**

CHKD:      DATE: AUG. 12/93      DRN: KS

**Model: UA-7D-TCD  
Dual Alarm Trip  
Calibration/Connection**

DWG. NO. : 104490-1    Sht 1 of 2    REV. A

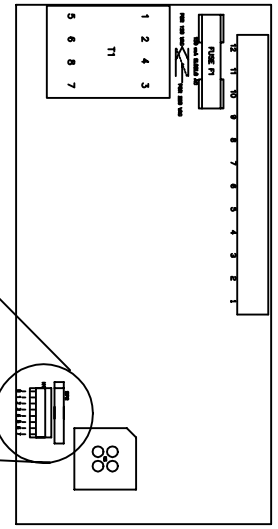
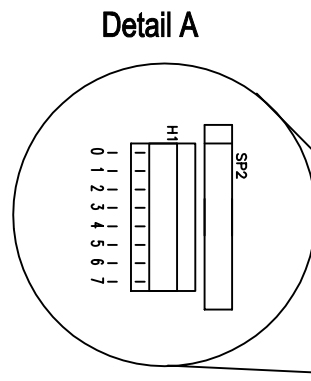
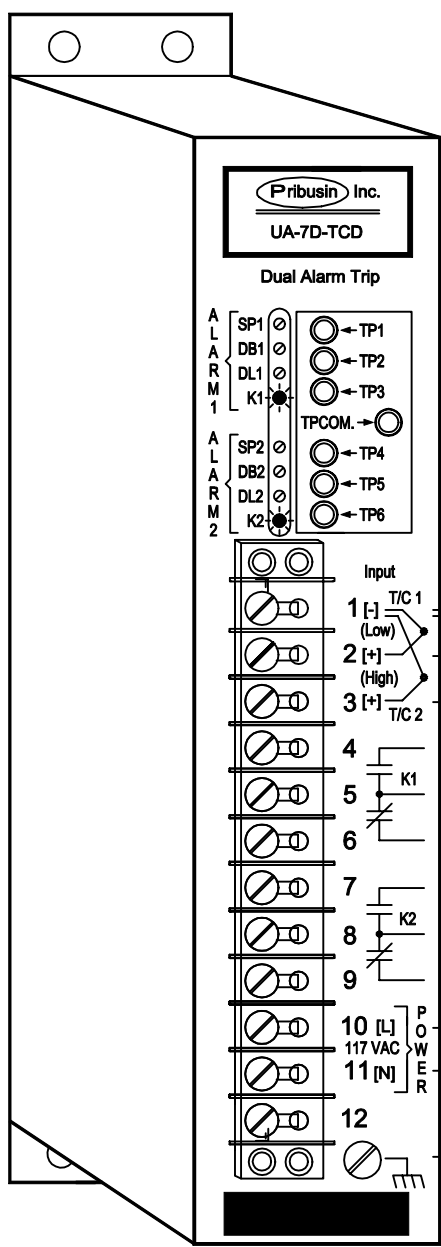

See Detail B for Test Setup.

T/C Input #1 (Low)

T/C Input #2 (High)

See Detail A for Jumper Location

Jumper	Out	In
H1-0	Always IN	Always IN
H1-1	K1 High Trip	K1 Low Trip
H1-2	K2 High Trip	K2 Low Trip
H1-3	K1 Norm. Eng.	K1 Norm. De-Eng.
H1-4	K2 Norm Eng.	K2 Norm. De-Eng.
H1-5	Always IN	Always IN
H1-6	ON Delay Only	OFF and ON Delay
H1-7	Always OUT	Always OUT

Power 117 VAC 60 Hz

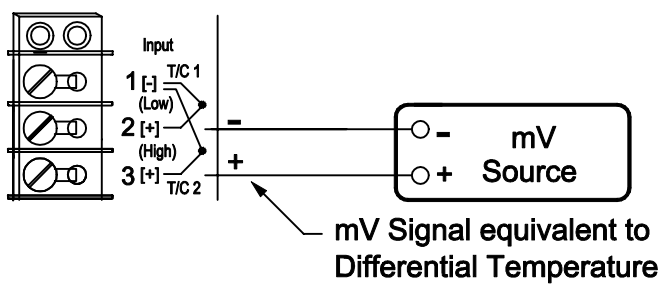

**Pribusin Inc. ©**

CHKD:	DATE: AUG. 12/93	DRN: KS
<b>Model: UA-7D-TCD</b> <b>Dual Alarm Trip</b> <b>Calibration/Connection</b>		
DWG. NO. : 104490-2	Sht 2 of 2	REV. A